

Trigonometrical Ratios of Standard Angles

Ex No: 27.1

Solution 1.

(i) $\sin 60^\circ \sin 30^\circ + \cos 30^\circ \cos 60^\circ$.

$$\sin 60^\circ = \frac{\sqrt{3}}{2}$$

$$\sin 30^\circ = \frac{1}{2}$$

$$\cos 30^\circ = \frac{\sqrt{3}}{2}$$

$$\cos 60^\circ = \frac{1}{2}$$

$$\begin{aligned}\sin 60^\circ \sin 30^\circ + \cos 30^\circ \cos 60^\circ &= \frac{\sqrt{3}}{2} \times \frac{1}{2} + \frac{\sqrt{3}}{2} \times \frac{1}{2} \\ &= \frac{\sqrt{3}}{4} + \frac{\sqrt{3}}{4} = \frac{2\sqrt{3}}{4} = \frac{\sqrt{3}}{2}\end{aligned}$$

(ii) $\sec 30^\circ \operatorname{cosec} 60^\circ + \cos 60^\circ \sin 30^\circ$.

$$\cos 30^\circ = \frac{\sqrt{3}}{2} \Rightarrow \sec 30^\circ = \frac{2}{\sqrt{3}}$$

$$\sin 60^\circ = \frac{\sqrt{3}}{2} \Rightarrow \operatorname{cosec} 60^\circ = \frac{2}{\sqrt{3}}$$

$$\cos 60^\circ = \frac{1}{2}, \sin 30^\circ = \frac{1}{2}$$

$$\sec 30^\circ \operatorname{cosec} 60^\circ + \cos 60^\circ \sin 30^\circ$$

$$\begin{aligned}&= \frac{2}{\sqrt{3}} \times \frac{2}{\sqrt{3}} + \frac{1}{2} \times \frac{1}{2} \\ &= \frac{4}{3} + \frac{1}{4} = \frac{16+3}{12} = \frac{19}{12}\end{aligned}$$

(iii) $\sec 45^\circ \sin 45^\circ - \sin 30^\circ \sec 60^\circ$.

$$\cos 45^\circ = \frac{1}{\sqrt{2}} \Rightarrow \sec 45^\circ = \sqrt{2}$$

$$\sin 45^\circ = \frac{1}{\sqrt{2}}$$

$$\sin 30^\circ = \frac{1}{2}$$

$$\cos 60^\circ = \frac{1}{2} \Rightarrow \sec 60^\circ = 2$$

$$\sec 45^\circ \sin 45^\circ - \sin 30^\circ \sec 60^\circ$$

$$= \sqrt{2} \times \frac{1}{\sqrt{2}} - \frac{1}{2} \times 2 = 1 - 1 = 0$$

$$(iv) \sin^2 30^\circ \sin^2 45^\circ + \sin^2 60^\circ \sin^2 90^\circ$$

$$\sin 30^\circ = \frac{1}{2}$$

$$\sin 45^\circ = \frac{1}{\sqrt{2}}$$

$$\sin 60^\circ = \frac{\sqrt{3}}{2}$$

$$\sin 90^\circ = 1$$

$$\sin^2 30^\circ \sin^2 45^\circ + \sin^2 60^\circ \sin^2 90^\circ$$

$$= \left(\frac{1}{2}\right)^2 \left(\frac{1}{\sqrt{2}}\right)^2 + \left(\frac{\sqrt{3}}{2}\right)^2 \cdot 1 = \frac{1}{4} \times \frac{1}{2} + \frac{3}{4}$$

$$= \frac{1}{8} + \frac{3}{4} = \frac{1+6}{8} = \frac{7}{8}$$

$$(v) \tan^2 30^\circ + \tan^2 60^\circ + \tan^2 45^\circ$$

$$\tan 30^\circ = \frac{1}{\sqrt{3}}$$

$$\tan 60^\circ = \sqrt{3}$$

$$\tan 45^\circ = 1$$

$$\tan^2 30^\circ + \tan^2 60^\circ + \tan^2 45^\circ$$

$$= \left(\frac{1}{\sqrt{3}}\right)^2 + (\sqrt{3})^2 + 1$$

$$= \frac{1}{3} + 3 + 1 = \frac{1+9+3}{3} = \frac{13}{3}$$

$$(vi) \sin^2 30^\circ \cos^2 45^\circ + 4 \tan^2 30^\circ + \sin^2 90^\circ + \cos^2 0^\circ$$

$$\sin 30^\circ = \frac{1}{2}$$

$$\cos 45^\circ = \frac{1}{\sqrt{2}}$$

$$\tan 30^\circ = \frac{1}{\sqrt{3}}$$

$$\sin 90^\circ = 1$$

$$\cos 0^\circ = 1$$

$$\sin^2 30^\circ \cos^2 45^\circ + 4 \tan^2 30^\circ + \sin^2 90^\circ + \cos^2 0^\circ$$

$$= \left(\frac{1}{2}\right)^2 \left(\frac{1}{\sqrt{2}}\right)^2 + 4 \left(\frac{1}{\sqrt{3}}\right)^2 + 1 + 1$$

$$= \frac{1}{4} \times \frac{1}{2} + \frac{4}{3} + 2 = \frac{1}{8} + \frac{4}{3} + 2$$

$$= \frac{3+32+48}{24} = \frac{83}{24}$$

$$(vii) \operatorname{cosec}^2 45^\circ \sec^2 30^\circ - \sin^2 30^\circ - 4 \cot^2 45^\circ + \sec^2 60^\circ$$

$$\sin 45^\circ = \frac{1}{\sqrt{2}}$$

$$\operatorname{cosec} 45^\circ = \frac{\sqrt{2}}{1}$$

$$\sin 30^\circ = \frac{1}{2} = \cos 60^\circ$$

$$\sec 60^\circ = 2$$

$$\cos 30^\circ = \frac{\sqrt{3}}{2}$$

$$\sec 30^\circ = \frac{2}{\sqrt{3}}$$

$$\tan 45^\circ = 1$$

$$\cot 45^\circ = 1$$

$$\operatorname{cosec}^2 45^\circ \sec^2 30^\circ - \sin^2 30^\circ - 4 \cot^2 45^\circ + \sec^2 60^\circ$$

$$= \left(\frac{\sqrt{2}}{1}\right)^2 \left(\frac{2}{\sqrt{3}}\right)^2 - \left(\frac{1}{2}\right)^2 - 4(1)^2 + (2)^2$$

$$= 2 \times \frac{4}{3} - \frac{1}{4} - 4 + 4 = \frac{8}{3} - \frac{1}{4} = \frac{32-3}{12} = \frac{29}{12}$$

$$(viii) \operatorname{cosec}^3 30^\circ \cos 60^\circ \tan^3 45^\circ \sin^2 90^\circ \sec^2 45^\circ \cot 30^\circ.$$

$$\sin 30^\circ = \frac{1}{2}$$

$$\operatorname{cosec} 30^\circ = 2$$

$$\cos 60^\circ = \frac{1}{2}$$

$$\sec 60^\circ = 2$$

$$\cos 45^\circ = \frac{1}{\sqrt{2}}$$

$$\sec 45^\circ = \sqrt{2}$$

$$\tan 45^\circ = 1$$

$$\sin 90^\circ = 1$$

$$\tan 30^\circ = \frac{1}{\sqrt{3}} \Rightarrow \cot 30^\circ = \sqrt{3}$$

$$\operatorname{cosec}^3 30^\circ \cos 60^\circ \tan^3 45^\circ \sin^2 90^\circ \sec^2 45^\circ \cot 30^\circ$$

$$= (2)^3 \left(\frac{1}{2}\right) (1)^3 (1)^2 (\sqrt{2})^2 (\sqrt{3})$$

$$(ix) (\sin 90^\circ + \sin 45^\circ + \sin 30^\circ)(\sin 90^\circ - \cos 45^\circ + \cos 60^\circ).$$

$$\sin 30^\circ = \frac{1}{2}$$

$$\sin 45^\circ = \frac{1}{\sqrt{2}}$$

$$\sin 90^\circ = 1$$

$$\cos 45^\circ = \frac{1}{\sqrt{2}}$$

$$\cos 60^\circ = \frac{1}{2}$$

$$(\sin 90^\circ + \sin 45^\circ + \sin 30^\circ)(\sin 90^\circ - \cos 45^\circ + \cos 60^\circ)$$

$$= \left(1 + \frac{1}{\sqrt{2}} + \frac{1}{2}\right) \left(1 - \frac{1}{\sqrt{2}} + \frac{1}{2}\right)$$

$$= \left(\frac{3}{2} + \frac{1}{\sqrt{2}}\right) \left(\frac{3}{2} - \frac{1}{\sqrt{2}}\right) = \left(\frac{3}{2}\right)^2 - \left(\frac{1}{\sqrt{2}}\right)^2$$

$$= \frac{9}{4} - \frac{1}{2} = \frac{9-2}{4} = \frac{7}{4}$$

$$(x) 4(\sin^4 30^\circ + \cos^4 60^\circ) - 3(\cos^2 45^\circ - \sin^2 90^\circ).$$

$$\sin 30^\circ = \frac{1}{2}$$

$$\sin 90^\circ = 1$$

$$\cos 45^\circ = \frac{1}{\sqrt{2}}$$

$$\cos 60^\circ = \frac{1}{2}$$

$$4(\sin^4 30^\circ + \cos^4 60^\circ) - 3(\cos^2 45^\circ - \sin^2 90^\circ)$$

$$= 4\left(\left(\frac{1}{2}\right)^4 + \left(\frac{1}{2}\right)^4\right) - 3\left(\left(\frac{1}{\sqrt{2}}\right)^2 - (1)^2\right)$$

$$= 4\left(\frac{1}{16} + \frac{1}{16}\right) - 3\left(\frac{1}{2} - 1\right) = 4 \times \frac{2}{16} + 3 \times \frac{1}{2} = \frac{1}{2} + \frac{3}{2} = \frac{4}{2} = 2$$

Solution 2.

$$(i) \quad \frac{\sin 30^\circ - \sin 90^\circ + 2 \cos 0^\circ}{\tan 30^\circ \tan 60^\circ}$$

$$\frac{\sin 30^\circ - \sin 90^\circ + 2 \cos 0^\circ}{\tan 30^\circ \tan 60^\circ}$$

$$= \frac{\frac{1}{2} - 1 + 2 \times 1}{\frac{1}{\sqrt{3}} \times \sqrt{3}}$$

$$= \frac{1}{\sqrt{3}} \times \sqrt{3}$$

$$= \frac{\frac{1}{2} - 1 + 2}{1}$$

$$= \frac{1}{2} - 1 + 2$$

$$= \frac{1}{2} + 1$$

$$= \frac{3}{2}$$

$$(ii) \quad \frac{\sin 30^\circ}{\sin 45^\circ} + \frac{\tan 45^\circ}{\sec 60^\circ} - \frac{\sin 60^\circ}{\cot 45^\circ} - \frac{\cos 30^\circ}{\sin 90^\circ}$$

$$\frac{\sin 30^\circ}{\sin 45^\circ} + \frac{\tan 45^\circ}{\sec 60^\circ} - \frac{\sin 60^\circ}{\cot 45^\circ} - \frac{\cos 30^\circ}{\sin 90^\circ}$$

$$= \frac{1}{\frac{1}{\sqrt{2}}} + \frac{1}{2} - \frac{\sqrt{3}}{1} - \frac{\sqrt{3}}{1}$$

$$= \frac{\sqrt{2}}{2} + \frac{1}{2} - \frac{\sqrt{3}}{2} - \frac{\sqrt{3}}{2}$$

$$= \frac{\sqrt{2} + 1 - 2\sqrt{3}}{2}$$

$$(iii) \quad \frac{\tan 45^\circ}{\operatorname{cosec} 30^\circ} + \frac{\sec 60^\circ}{\cot 45^\circ} - \frac{5 \sin 90^\circ}{2 \cos 0^\circ}$$

$$\frac{\tan 45^\circ}{\operatorname{cosec} 30^\circ} + \frac{\sec 60^\circ}{\cot 45^\circ} - \frac{5 \sin 90^\circ}{2 \cos 0^\circ}$$

$$= \frac{1}{2} + \frac{2}{1} - \frac{5 \times 1}{2 \times 1}$$

$$= \frac{1}{2} + \frac{2}{1} - \frac{5}{2}$$

$$= \frac{1 + 4 - 5}{2}$$

$$= 0$$

$$(iv) \quad \frac{\tan^2 60^\circ + 4 \cos^2 45^\circ + 3 \sec^2 30^\circ + 5 \cos 90^\circ}{\operatorname{cosec} 30^\circ + \sec 60^\circ - \cot^2 30^\circ}$$

$$\frac{\tan^2 60^\circ + 4 \cos^2 45^\circ + 3 \sec^2 30^\circ + 5 \cos 90^\circ}{\operatorname{cosec} 30^\circ + \sec 60^\circ - \cot^2 30^\circ}$$

$$= \frac{(\sqrt{3})^2 + 4 \times \left(\frac{1}{\sqrt{2}}\right)^2 + 3 \times \left(\frac{2}{\sqrt{3}}\right)^2 + 5 \times 0}{2 + 2 - (\sqrt{3})^2}$$

$$= \frac{3 + 4 \times \frac{1}{2} + 3 \times \frac{4}{3} + 0}{2 + 2 - 3}$$

$$(v) \quad \frac{4}{\cot^2 30^\circ} + \frac{1}{\sin^2 60^\circ} - \cos^2 45^\circ$$

$$\frac{4}{\cot^2 30^\circ} + \frac{1}{\sin^2 60^\circ} - \cos^2 45^\circ$$

$$= \frac{4}{(\sqrt{3})^2} + \frac{1}{\left(\frac{\sqrt{3}}{2}\right)^2} - \left(\frac{1}{\sqrt{2}}\right)^2$$

$$= \frac{4}{3} + \frac{1}{\frac{3}{4}} - \frac{1}{2}$$

$$= \frac{4}{3} + \frac{4}{3} - \frac{1}{2}$$

$$\begin{aligned} &= \frac{2+2-3}{3+2+4} \\ &= \frac{1}{9} \end{aligned}$$

$$\begin{aligned} &= \frac{8+8-3}{6} \\ &= \frac{13}{6} \end{aligned}$$

Solution 3a.

$$\begin{aligned} \text{L.H.S.} &= \sin 60^\circ \cdot \cos 30^\circ - \cos 60^\circ \cdot \sin 30^\circ \\ &= \frac{\sqrt{3}}{2} \times \frac{\sqrt{3}}{2} - \frac{1}{2} \times \frac{1}{2} \\ &= \frac{3}{4} - \frac{1}{4} \\ &= \frac{2}{4} \\ &= \frac{1}{2} \\ &= \text{R.H.S.} \end{aligned}$$

Solution 3b.

$$\begin{aligned} \text{L.H.S.} &= \cos 60^\circ \cdot \cos 30^\circ - \sin 60^\circ \cdot \sin 30^\circ \\ &= \frac{1}{2} \times \frac{\sqrt{3}}{2} - \frac{\sqrt{3}}{2} \times \frac{1}{2} \\ &= \frac{\sqrt{3}}{4} - \frac{\sqrt{3}}{4} \\ &= 0 \\ &= \text{R.H.S.} \end{aligned}$$

Solution 3c.

$$\begin{aligned} \text{L.H.S.} &= \sec^2 45^\circ - \tan^2 45^\circ \\ &= (\sqrt{2})^2 - (1)^2 \\ &= 2 - 1 \\ &= 1 \\ &= \text{R.H.S.} \end{aligned}$$

Solution 3d.

$$\begin{aligned}\text{L.H.S.} &= \left(\frac{\cot 30^\circ + 1}{\cot 30^\circ - 1} \right)^2 \\ &= \left(\frac{\sqrt{3} + 1}{\sqrt{3} - 1} \right)^2 \\ &= \left(\frac{\sqrt{3} + 1}{\sqrt{3} - 1} \times \frac{\sqrt{3} + 1}{\sqrt{3} + 1} \right)^2 \\ &= \frac{(\sqrt{3})^2 + (1)^2 + 2\sqrt{3}}{(\sqrt{3})^2 + (1)^2 - 2\sqrt{3}} \\ &= \frac{3 + 1 + 2\sqrt{3}}{3 + 1 - 2\sqrt{3}} \\ &= \frac{4 + 2\sqrt{3}}{4 - 2\sqrt{3}} \\ &= \frac{2(2 + \sqrt{3})}{2(2 - \sqrt{3})} \\ &= \frac{2 + \sqrt{3}}{2 - \sqrt{3}} \\ &= \frac{\frac{2}{\sqrt{3}} + 1}{\frac{2}{\sqrt{3}} - 1} \\ &= \frac{\sec 30^\circ + 1}{\sec 30^\circ - 1} \\ &= \text{R.H.S.}\end{aligned}$$

Solution 4a.

$$\begin{aligned}2 \cos A &= 1 \\ \Rightarrow \cos A &= \frac{1}{2} \\ \Rightarrow \cos A &= \cos 60^\circ \\ \Rightarrow A &= 60^\circ\end{aligned}$$

Solution 4b.

$$2 \sin 2A = 1$$

$$\Rightarrow \sin 2A = \frac{1}{2}$$

$$\Rightarrow \sin 2A = \sin 30^\circ$$

$$\Rightarrow 2A = 30^\circ$$

$$\Rightarrow A = 15^\circ$$

Solution 4c.

$$\operatorname{cosec} 3A = \frac{2}{\sqrt{3}}$$

$$\Rightarrow \operatorname{cosec} 3A = \operatorname{cosec} 60^\circ$$

$$\Rightarrow 3A = 60^\circ$$

$$\Rightarrow A = 20^\circ$$

Solution 4d.

$$2 \cos 3A = 1$$

$$\Rightarrow \cos 3A = \frac{1}{2}$$

$$\Rightarrow \cos 3A = \cos 60^\circ$$

$$\Rightarrow 3A = 60^\circ$$

$$\Rightarrow A = 20^\circ$$

Solution 4e.

$$\sqrt{3} \cot A = 1$$

$$\Rightarrow \cot A = \frac{1}{\sqrt{3}}$$

$$\Rightarrow \cot A = \cot 60^\circ$$

$$\Rightarrow A = 60^\circ$$

Solution 4f.

$$\cot 3A = 1$$

$$\Rightarrow \cot 3A = \cot 45^\circ$$

$$\Rightarrow 3A = 45^\circ$$

$$\Rightarrow A = 15^\circ$$

Solution 5a.

$$\begin{aligned}(1 - \operatorname{cosec} A)(2 - \sec A) &= 0 \\ \Rightarrow 1 - \operatorname{cosec} A = 0 \text{ and } 2 - \sec A = 0 \\ \Rightarrow \operatorname{cosec} A = 1 \text{ and } \sec A = 2 \\ \Rightarrow \operatorname{cosec} A = \operatorname{cosec} 90^\circ \text{ and } \sec A = \sec 60^\circ \\ \Rightarrow A = 90^\circ \text{ and } A = 60^\circ\end{aligned}$$

Solution 5b.

$$\begin{aligned}(2 - \operatorname{cosec} 2A) \cos 3A &= 0 \\ \Rightarrow 2 - \operatorname{cosec} 2A = 0 \text{ and } \cos 3A = 0 \\ \Rightarrow \operatorname{cosec} 2A = 2 \text{ and } \cos 3A = 0 \\ \Rightarrow \operatorname{cosec} 2A = \operatorname{cosec} 30^\circ \text{ and } \cos 3A = \cos 90^\circ \\ \Rightarrow 2A = 30^\circ \text{ and } 3A = 90^\circ \\ \Rightarrow A = 15^\circ \text{ and } A = 30^\circ\end{aligned}$$

Solution 6.

$$\begin{aligned}\sin \alpha + \cos \beta &= 1 \\ \Rightarrow \sin 90^\circ + \cos \beta &= 1 \\ \Rightarrow 1 + \cos \beta &= 1 \\ \Rightarrow \cos \beta &= 0 \\ \Rightarrow \cos \beta &= \cos 90^\circ \\ \Rightarrow \beta &= 90^\circ\end{aligned}$$

Solution 7a.

$$\begin{aligned}\sin \frac{\theta}{3} &= 1 \\ \Rightarrow \sin \frac{\theta}{3} &= \sin 90^\circ \\ \Rightarrow \frac{\theta}{3} &= 90^\circ \\ \Rightarrow \theta &= 270^\circ\end{aligned}$$

Solution 7b.

$$\cot^2 (\theta - 5)^\circ = 3$$

$$\Rightarrow \cot(\theta - 5)^\circ = \sqrt{3}$$

$$\Rightarrow \cot(\theta - 5)^\circ = \cot 30^\circ$$

$$\Rightarrow (\theta - 5)^\circ = 30^\circ$$

$$\Rightarrow \theta = 30^\circ + 5^\circ$$

$$\Rightarrow \theta = 35^\circ$$

Solution 7c.

$$\sec\left(\frac{\theta}{2} + 10^\circ\right) = \frac{2}{\sqrt{3}}$$

$$\Rightarrow \sec\left(\frac{\theta}{2} + 10^\circ\right) = \sec 30^\circ$$

$$\Rightarrow \frac{\theta}{2} + 10^\circ = 30^\circ$$

$$\Rightarrow \frac{\theta}{2} = 20^\circ$$

$$\Rightarrow \theta = 40^\circ$$

Solution 8.

(i) $2 \sin 3x = \sqrt{3}$

$$2 \sin 3x = \sqrt{3}$$

$$\Rightarrow \sin 3x = \frac{\sqrt{3}}{2}$$

$$\Rightarrow \sin 3x = \sin 60^\circ$$

$$\Rightarrow 3x = 60^\circ$$

$$\Rightarrow x = 20^\circ$$

(ii) $2 \sin \frac{x}{2} = 1$

$$2 \sin \frac{x}{2} = 1$$

$$\Rightarrow \sin \frac{x}{2} = \frac{1}{2}$$

$$\Rightarrow \sin \frac{x}{2} = \sin 30^\circ$$

$$\Rightarrow \frac{x}{2} = 30^\circ$$

$$\Rightarrow x = 60^\circ$$

(iii) $\sqrt{3} \sin x = \cos x$

$$\sqrt{3} \sin x = \cos x$$

$$\Rightarrow \frac{\sin x}{\cos x} = \frac{1}{\sqrt{3}}$$

$$\Rightarrow \tan x = \tan 30^\circ$$

$$\Rightarrow x = 30^\circ$$

(iv) $\tan x = \sin 45^\circ \cos 45^\circ + \sin 30^\circ$

$$\tan x = \sin 45^\circ \cos 45^\circ + \sin 30^\circ$$

$$\Rightarrow \tan x = \frac{1}{\sqrt{2}} \times \frac{1}{\sqrt{2}} + \frac{1}{2}$$

$$\Rightarrow \tan x = \frac{1}{2} + \frac{1}{2}$$

$$\Rightarrow \tan x = 1$$

$$\Rightarrow \tan x = \tan 45^\circ$$

$$\Rightarrow x = 45^\circ$$

(v) $\sqrt{3} \tan 2x = \cos 60^\circ + \sin 45^\circ \cos 45^\circ$

$$\sqrt{3} \tan 2x = \cos 60^\circ + \sin 45^\circ \cos 45^\circ$$

$$\Rightarrow \sqrt{3} \tan 2x = \frac{1}{2} + \frac{1}{\sqrt{2}} \times \frac{1}{\sqrt{2}}$$

$$\Rightarrow \sqrt{3} \tan 2x = \frac{1}{2} + \frac{1}{2}$$

$$\Rightarrow \sqrt{3} \tan 2x = 1$$

$$\Rightarrow \tan 2x = \frac{1}{\sqrt{3}}$$

$$\Rightarrow \tan 2x = \tan 30^\circ$$

$$\Rightarrow 2x = 30^\circ$$

$$\Rightarrow x = 15^\circ$$

$$(vi) \cos 2x = \cos 60^\circ \cos 30^\circ + \sin 60^\circ \sin 30^\circ$$

$$\cos 2x = \cos 60^\circ \cos 30^\circ + \sin 60^\circ \sin 30^\circ$$

$$\Rightarrow \cos 2x = \frac{1}{2} \times \frac{\sqrt{3}}{2} + \frac{\sqrt{3}}{2} \times \frac{1}{2}$$

$$\Rightarrow \cos 2x = \frac{\sqrt{3}}{4} + \frac{\sqrt{3}}{4}$$

$$\Rightarrow \cos 2x = \frac{2\sqrt{3}}{4}$$

$$\Rightarrow \cos 2x = \frac{\sqrt{3}}{2}$$

$$\Rightarrow \cos 2x = \cos 30^\circ$$

$$\Rightarrow 2x = 30^\circ$$

$$\Rightarrow x = 15^\circ$$

Solution 9.

$$\sin \theta = \cos \theta$$

$$\Rightarrow \frac{\sin \theta}{\cos \theta} = \frac{\cos \theta}{\cos \theta}$$

$$\Rightarrow \tan \theta = 1$$

$$\Rightarrow \tan \theta = \tan 45^\circ$$

$$\Rightarrow \theta = 45^\circ$$

Solution 10.

$$\tan \theta = \cot \theta$$

$$\Rightarrow \tan \theta = \frac{1}{\tan \theta}$$

$$\Rightarrow \tan^2 \theta = 1$$

$$\Rightarrow \tan \theta = 1$$

$$\Rightarrow \theta = 45^\circ$$

Solution 11.

$$\text{Given: } \sqrt{2} = 1.414 \text{ and } \sqrt{3} = 1.732$$

$$a. \tan 60^\circ = \sqrt{3} = 1.732 = 1.73$$

$$b. \sin 45^\circ \cos 30^\circ = \frac{1}{\sqrt{2}} \times \frac{\sqrt{3}}{2} = \frac{\sqrt{3}}{2\sqrt{2}} = \frac{1.732}{2 \times 1.414} = \frac{1.732}{2.828} = 0.61$$

Solution 12a.

Given : $\theta = 30^\circ$

$$\begin{aligned}\text{L.H.S.} &= \tan 2\theta \\ &= \tan 2 \times 30^\circ \\ &= \tan 60^\circ \\ &= \sqrt{3}\end{aligned}$$

$$\begin{aligned}\text{R.H.S.} &= \frac{2 \tan \theta}{1 - \tan^2 \theta} \\ &= \frac{2 \tan 30^\circ}{1 - \tan^2 30^\circ} \\ &= \frac{2 \times \frac{1}{\sqrt{3}}}{1 - \left(\frac{1}{\sqrt{3}}\right)^2} \\ &= \frac{\frac{2}{\sqrt{3}}}{1 - \frac{1}{3}} \\ &= \frac{\frac{2}{\sqrt{3}}}{\frac{2}{3}} \\ &= \frac{2}{\sqrt{3}} \times \frac{3}{2} \\ &= \sqrt{3}\end{aligned}$$

\Rightarrow L.H.S. = R.H.S.

$$\Rightarrow \tan 2\theta = \frac{2 \tan \theta}{1 - \tan^2 \theta}$$

Solution 12b.

Given : $\theta = 30^\circ$

$$\begin{aligned}\text{L.H.S.} &= \sin 2\theta \\ &= \sin 2 \times 30^\circ \\ &= \sin 60^\circ \\ &= \frac{\sqrt{3}}{2}\end{aligned}$$

$$\begin{aligned}\text{R.H.S.} &= \frac{2 \tan \theta}{1 + \tan^2 \theta} \\ &= \frac{2 \tan 30^\circ}{1 + \tan^2 30^\circ} \\ &= \frac{2 \times \frac{1}{\sqrt{3}}}{1 + \left(\frac{1}{\sqrt{3}}\right)^2} \\ &= \frac{\frac{2}{\sqrt{3}}}{1 + \frac{1}{3}} \\ &= \frac{\frac{2}{\sqrt{3}}}{\frac{4}{3}} \\ &= \frac{2}{\sqrt{3}} \times \frac{3}{4} \\ &= \frac{\sqrt{3}}{2}\end{aligned}$$

\Rightarrow L.H.S. = R.H.S.

$$\Rightarrow \sin 2\theta = \frac{2 \tan \theta}{1 + \tan^2 \theta}$$

Solution 12c.Given : $\theta = 30^\circ$

$$\cos 2\theta = \cos 2 \times 30^\circ = \cos 60^\circ = \frac{1}{2}$$

$$\frac{1 - \tan^2 \theta}{1 + \tan^2 \theta} = \frac{1 - \tan^2 30^\circ}{1 + \tan^2 30^\circ} = \frac{1 - \left(\frac{1}{\sqrt{3}}\right)^2}{1 + \left(\frac{1}{\sqrt{3}}\right)^2} = \frac{1 - \frac{1}{3}}{1 + \frac{1}{3}} = \frac{\frac{2}{3}}{\frac{4}{3}} = \frac{1}{2}$$

$$\cos^4 \theta - \sin^4 \theta = \cos^4 30^\circ - \sin^4 30^\circ = \left(\frac{\sqrt{3}}{2}\right)^4 - \left(\frac{1}{2}\right)^4 = \frac{9}{16} - \frac{1}{16} = \frac{8}{16} = \frac{1}{2}$$

$$2\cos^2 \theta - 1 = 2\cos^2 30^\circ - 1 = 2\left(\frac{\sqrt{3}}{2}\right)^2 - 1 = 2 \times \frac{3}{4} - 1 = \frac{3}{2} - 1 = \frac{1}{2}$$

$$1 - 2\sin^2 \theta = 1 - 2\sin^2 30^\circ = 1 - 2\left(\frac{1}{2}\right)^2 = 1 - 2 \times \frac{1}{4} = 1 - \frac{1}{2} = \frac{1}{2}$$

$$\Rightarrow \cos 2\theta = \frac{1 - \tan^2 \theta}{1 + \tan^2 \theta} = \cos^4 \theta - \sin^4 \theta = 2\cos^2 \theta - 1 = 1 - 2\sin^2 \theta$$

Solution 12d.Given : $\theta = 30^\circ$

$$\sin 3\theta = \sin 3 \times 30^\circ$$

$$= \sin 90^\circ$$

$$= 1$$

$$4 \sin \theta \sin(60^\circ - \theta) \sin(60^\circ + \theta) = 4 \sin 30^\circ \times \sin(60^\circ - 30^\circ) \times \sin(60^\circ + 30^\circ)$$

$$= 4 \sin 30^\circ \times \sin 30^\circ \times \sin 90^\circ$$

$$= 4 \times \frac{1}{2} \times \frac{1}{2} \times 1$$

$$= 1$$

$$\Rightarrow \sin 3\theta = 4 \sin \theta \sin(60^\circ - \theta) \sin(60^\circ + \theta)$$

Solution 12e.

$$\text{Given : } \theta = 30^\circ$$

$$\begin{aligned} 1 - \sin 2\theta &= 1 - \sin 2 \times 30^\circ \\ &= 1 - \sin 60^\circ \\ &= 1 - \frac{\sqrt{3}}{2} \\ &= \frac{2 - \sqrt{3}}{2} \end{aligned}$$

$$\begin{aligned} (\sin \theta - \cos \theta)^2 &= \sin^2 \theta + \cos^2 \theta - 2 \sin \theta \cos \theta \\ &= 1 - 2 \times \sin 30^\circ \times \cos 30^\circ \\ &= 1 - 2 \times \frac{1}{2} \times \frac{\sqrt{3}}{2} \\ &= 1 - \frac{\sqrt{3}}{2} \\ &= \frac{2 - \sqrt{3}}{2} \end{aligned}$$

$$\Rightarrow 1 - \sin 2\theta = (\sin \theta - \cos \theta)^2$$

Solution 13a.

$$2\theta = 30^\circ$$

$$\Rightarrow \theta = 15^\circ$$

$$\begin{aligned} \therefore \frac{\sin 3\theta - 2 \sin 4\theta}{\cos 3\theta - 2 \cos 4\theta} &= \frac{\sin 3 \times 15^\circ - 2 \sin 4 \times 15^\circ}{\cos 3 \times 15^\circ - 2 \cos 4 \times 15^\circ} \\ &= \frac{\sin 45^\circ - 2 \sin 60^\circ}{\cos 45^\circ - 2 \cos 60^\circ} \\ &= \frac{\frac{1}{\sqrt{2}} - 2 \times \frac{\sqrt{3}}{2}}{\frac{1}{\sqrt{2}} - 2 \times \frac{1}{2}} \\ &= \frac{\frac{1}{\sqrt{2}} - \sqrt{3}}{\frac{1}{\sqrt{2}} - 1} \\ &= \frac{1 - \sqrt{6}}{\sqrt{2}} \\ &= \frac{1 - \sqrt{6}}{1 - \sqrt{2}} \\ &= \frac{1 - \sqrt{6}}{1 - \sqrt{2}} \times \frac{1 + \sqrt{2}}{1 + \sqrt{2}} \\ &= \frac{1 + \sqrt{2} - \sqrt{6} - \sqrt{12}}{1 - 2} \\ &= \frac{1 + \sqrt{2} - \sqrt{6} - 2\sqrt{3}}{-1} \\ &= 2\sqrt{3} + \sqrt{6} - \sqrt{2} - 1 \end{aligned}$$

Solution 13b.

$$\theta = 30^\circ$$

$$\frac{(1 - \cos \theta)(1 + \cos \theta)}{(1 - \sin \theta)(1 + \sin \theta)} = \frac{1 - \cos^2 \theta}{1 - \sin^2 \theta}$$

$$= \frac{1 - \cos^2 30^\circ}{1 - \sin^2 30^\circ}$$

$$= \frac{1 - \left(\frac{\sqrt{3}}{2}\right)^2}{1 - \left(\frac{1}{2}\right)^2}$$

$$= \frac{1 - \frac{3}{4}}{1 - \frac{1}{4}}$$

$$= \frac{\frac{1}{4}}{\frac{3}{4}}$$

$$= \frac{1}{3}$$

Solution 14.

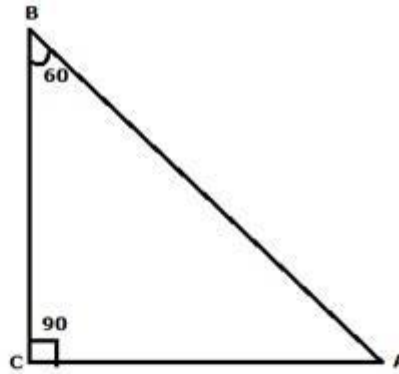

$$\angle B = 60^\circ$$

$$\angle C = 90^\circ \quad (\text{Since triangle ABC is right angled at C})$$

$$\angle A + \angle B + \angle C = 180^\circ$$

$$\angle A + 60^\circ + 90^\circ = 180^\circ$$

$$\angle A = 180^\circ - 150^\circ$$

$$\angle A = 30^\circ$$

Now,

$$\sin 60^\circ = \frac{AC}{AB}$$

$$\Rightarrow AC = \sin 60^\circ \times AB$$

$$\Rightarrow AC = \frac{\sqrt{3}}{2} \times 15$$

$$\Rightarrow AC = \frac{15\sqrt{3}}{2} \text{ units}$$

Also,

$$\cos 60^\circ = \frac{BC}{AB}$$

$$\Rightarrow BC = \cos 60^\circ \times AB$$

$$\Rightarrow BC = \frac{1}{2} \times 15$$

$$\Rightarrow BC = 7.5 \text{ units}$$

Solution 15.

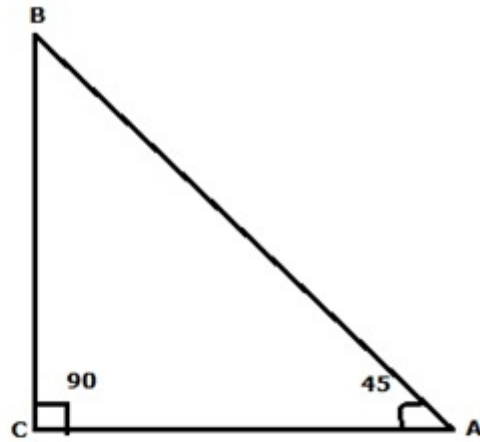

$$2 \quad \angle C = 90^\circ, \angle A = 45^\circ$$

$$\angle A + \angle B + \angle C = 180^\circ$$

$$45^\circ + \angle B + 90^\circ = 180^\circ$$

$$\angle B = 180^\circ - 135^\circ$$

$$\angle B = 45^\circ$$

$$\sin 45^\circ = \frac{BC}{AB}$$

$$\Rightarrow AB = \frac{BC}{\sin 45^\circ}$$

$$\Rightarrow AB = \frac{7}{\frac{1}{\sqrt{2}}}$$

$$\Rightarrow AB = 7\sqrt{2} \text{ units}$$

Also,

$$\tan 45^\circ = \frac{BC}{AC}$$

$$\Rightarrow AC = \frac{BC}{\tan 45^\circ}$$

$$\Rightarrow AC = \frac{7}{1}$$

$$\Rightarrow AC = 7 \text{ units}$$

Solution 16a.

$$A = 30^\circ \text{ and } B = 60^\circ$$

$$\begin{aligned}\text{L.H.S.} &= \sin (A + B) \\ &= \sin (30^\circ + 60^\circ) \\ &= \sin 90^\circ \\ &= 1\end{aligned}$$

$$\begin{aligned}\text{R.H.S.} &= \sin A \cos B + \cos A \sin B \\ &= \sin 30^\circ \times \cos 60^\circ + \cos 30^\circ \times \sin 60^\circ \\ &= \frac{1}{2} \times \frac{1}{2} + \frac{\sqrt{3}}{2} \times \frac{\sqrt{3}}{2} \\ &= \frac{1}{4} + \frac{3}{4} \\ &= \frac{4}{4} \\ &= 1\end{aligned}$$

$$\Rightarrow \sin (A + B) = \sin A \cos B + \cos A \sin B$$

Solution 16b.

$$A = 30^\circ \text{ and } B = 60^\circ$$

$$\begin{aligned}\text{L.H.S.} &= \cos (A + B) \\ &= \cos (30^\circ + 60^\circ) \\ &= \cos 90^\circ \\ &= 0\end{aligned}$$

$$\begin{aligned}\text{R.H.S.} &= \cos A \cos B - \sin A \sin B \\ &= \cos 30^\circ \times \cos 60^\circ - \sin 30^\circ \times \sin 60^\circ \\ &= \frac{\sqrt{3}}{2} \times \frac{1}{2} - \frac{1}{2} \times \frac{\sqrt{3}}{2} \\ &= \frac{\sqrt{3}}{4} - \frac{\sqrt{3}}{4} \\ &= 0\end{aligned}$$

$$\Rightarrow \cos (A + B) = \cos A \cos B - \sin A \sin B$$

Solution 16c.

$$A = 30^\circ \text{ and } B = 60^\circ$$

$$\begin{aligned} \text{L.H.S.} &= \frac{\sin(A+B)}{\cos A \cdot \cos B} \\ &= \frac{\sin(30^\circ + 60^\circ)}{\cos 30^\circ \times \cos 60^\circ} \\ &= \frac{\sin 90^\circ}{\cos 30^\circ \times \cos 60^\circ} \\ &= \frac{1}{\frac{\sqrt{3}}{2} \times \frac{1}{2}} \\ &= \frac{4}{\sqrt{3}} \end{aligned}$$

$$\begin{aligned} \text{R.H.S.} &= \tan A + \tan B \\ &= \tan 30^\circ + \tan 60^\circ \\ &= \frac{1}{\sqrt{3}} + \sqrt{3} \\ &= \frac{1+3}{\sqrt{3}} \\ &= \frac{4}{\sqrt{3}} \end{aligned}$$

$$\Rightarrow \frac{\sin(A+B)}{\cos A \cdot \cos B} = \tan A + \tan B$$

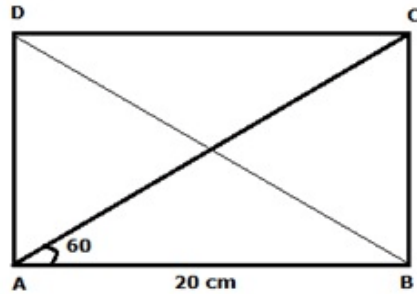
Solution 16.

In $\triangle ABC$,

$$\tan 60^\circ = \frac{BC}{AB}$$

$$\Rightarrow BC = \tan 60^\circ \times AB$$

$$\Rightarrow BC = \sqrt{3} \times 20$$

$$\Rightarrow BC = 20\sqrt{3}\text{cm}$$

$$\cos 60^\circ = \frac{AB}{AC}$$

$$\Rightarrow AC = \frac{AB}{\cos 60^\circ}$$

$$\Rightarrow AC = \frac{20}{\frac{1}{2}}$$

$$\Rightarrow AC = 20 \times 2 = 40\text{cm}$$

Since diagonals of a rectangle are equal, therefore $BD = AC = 40\text{ cm}$

Solution 16a.

$$A = 30^\circ \text{ and } B = 60^\circ$$

$$\begin{aligned} \text{L.H.S.} &= \sin (A + B) \\ &= \sin (30^\circ + 60^\circ) \\ &= \sin 90^\circ \\ &= 1 \end{aligned}$$

$$\begin{aligned} \text{R.H.S.} &= \sin A \cos B + \cos A \sin B \\ &= \sin 30^\circ \times \cos 60^\circ + \cos 30^\circ \times \sin 60^\circ \\ &= \frac{1}{2} \times \frac{1}{2} + \frac{\sqrt{3}}{2} \times \frac{\sqrt{3}}{2} \\ &= \frac{1}{4} + \frac{3}{4} \\ &= \frac{4}{4} \\ &= 1 \end{aligned}$$

$$\Rightarrow \sin (A + B) = \sin A \cos B + \cos A \sin B$$

Solution 16b.

$$A = 30^\circ \text{ and } B = 60^\circ$$

$$\begin{aligned} \text{L.H.S.} &= \cos (A + B) \\ &= \cos (30^\circ + 60^\circ) \\ &= \cos 90^\circ \\ &= 0 \end{aligned}$$

$$\begin{aligned} \text{R.H.S.} &= \cos A \cos B - \sin A \sin B \\ &= \cos 30^\circ \times \cos 60^\circ - \sin 30^\circ \times \sin 60^\circ \\ &= \frac{\sqrt{3}}{2} \times \frac{1}{2} - \frac{1}{2} \times \frac{\sqrt{3}}{2} \\ &= \frac{\sqrt{3}}{4} - \frac{\sqrt{3}}{4} \\ &= 0 \end{aligned}$$

$$\Rightarrow \cos (A + B) = \cos A \cos B - \sin A \sin B$$

Solution 16c.

$$A = 30^\circ \text{ and } B = 60^\circ$$

$$\begin{aligned} \text{L.H.S.} &= \frac{\sin (A + B)}{\cos A \cdot \cos B} \\ &= \frac{\sin (30^\circ + 60^\circ)}{\cos 30^\circ \times \cos 60^\circ} \\ &= \frac{\sin 90^\circ}{\cos 30^\circ \times \cos 60^\circ} \\ &= \frac{1}{\frac{\sqrt{3}}{2} \times \frac{1}{2}} \\ &= \frac{4}{\sqrt{3}} \end{aligned}$$

$$\begin{aligned} \text{R.H.S.} &= \tan A + \tan B \\ &= \tan 30^\circ + \tan 60^\circ \\ &= \frac{1}{\sqrt{3}} + \sqrt{3} \\ &= \frac{1 + 3}{\sqrt{3}} \\ &= \frac{4}{\sqrt{3}} \end{aligned}$$

$$\Rightarrow \frac{\sin (A + B)}{\cos A \cdot \cos B} = \tan A + \tan B$$

Solution 16d.

$$A = 30^\circ \text{ and } B = 60^\circ$$

$$\begin{aligned}\text{L.H.S.} &= \cos (A + B) \\ &= \cos (30^\circ + 60^\circ) \\ &= \cos 90^\circ \\ &= 0\end{aligned}$$

$$\begin{aligned}\text{R.H.S.} &= \cos A \cos B - \sin A \sin B \\ &= \cos 30^\circ \times \cos 60^\circ - \sin 30^\circ \times \sin 60^\circ \\ &= \frac{\sqrt{3}}{2} \times \frac{1}{2} - \frac{1}{2} \times \frac{\sqrt{3}}{2} \\ &= \frac{\sqrt{3}}{4} - \frac{\sqrt{3}}{4} \\ &= 0\end{aligned}$$

$$\Rightarrow \cos (A + B) = \cos A \cos B - \sin A \sin B$$

Solution 17a.

$$A = B = 45^\circ$$

$$\begin{aligned}\text{L.H.S.} &= \sin (A - B) \\ &= \sin (45^\circ - 45^\circ) \\ &= \sin 0^\circ \\ &= 0\end{aligned}$$

$$\begin{aligned}\text{R.H.S.} &= \sin A \cos B - \cos A \sin B \\ &= \sin 45^\circ \times \cos 45^\circ - \cos 45^\circ \times \sin 45^\circ \\ &= \frac{1}{\sqrt{2}} \times \frac{1}{\sqrt{2}} - \frac{1}{\sqrt{2}} \times \frac{1}{\sqrt{2}} \\ &= \frac{1}{2} - \frac{1}{2} \\ &= 0\end{aligned}$$

$$\Rightarrow \sin (A - B) = \sin A \cos B - \cos A \sin B$$

Solution 17b.

$$A = B = 45^\circ$$

$$\begin{aligned}\text{L.H.S.} &= \cos(A - B) \\ &= \cos(45^\circ - 45^\circ) \\ &= \cos 0^\circ \\ &= 1\end{aligned}$$

$$\begin{aligned}\text{R.H.S.} &= \cos A \cos B + \sin A \sin B \\ &= \cos 45^\circ \times \cos 45^\circ + \sin 45^\circ \times \sin 45^\circ \\ &= \frac{1}{\sqrt{2}} \times \frac{1}{\sqrt{2}} + \frac{1}{\sqrt{2}} \times \frac{1}{\sqrt{2}} \\ &= \frac{1}{2} + \frac{1}{2} \\ &= 1\end{aligned}$$

$$\Rightarrow \cos(A - B) = \cos A \cos B + \sin A \sin B$$

Solution 18.

$$\text{Let } A = 45^\circ \text{ and } B = 30^\circ$$

Then,

$$\begin{aligned}\sin(A - B) &= \sin A \cos B - \cos A \sin B \\ \Rightarrow \sin(45^\circ - 30^\circ) &= \sin 45^\circ \cos 30^\circ - \cos 45^\circ \sin 30^\circ \\ \Rightarrow \sin 15^\circ &= \frac{1}{\sqrt{2}} \times \frac{\sqrt{3}}{2} - \frac{1}{\sqrt{2}} \times \frac{1}{2} \\ \Rightarrow \sin 15^\circ &= \frac{\sqrt{3}}{2\sqrt{2}} - \frac{1}{2\sqrt{2}} \\ \Rightarrow \sin 15^\circ &= \frac{(\sqrt{3} - 1)}{2\sqrt{2}}\end{aligned}$$

$$\begin{aligned}\cos(A - B) &= \cos A \cos B + \sin A \sin B \\ \Rightarrow \cos(45^\circ - 30^\circ) &= \cos 45^\circ \cos 30^\circ + \sin 45^\circ \sin 30^\circ \\ \Rightarrow \cos 15^\circ &= \frac{1}{\sqrt{2}} \times \frac{\sqrt{3}}{2} + \frac{1}{\sqrt{2}} \times \frac{1}{2} \\ \Rightarrow \cos 15^\circ &= \frac{\sqrt{3}}{2\sqrt{2}} + \frac{1}{2\sqrt{2}} \\ \Rightarrow \cos 15^\circ &= \frac{(\sqrt{3} + 1)}{2\sqrt{2}}\end{aligned}$$

Solution 19a.

Since $\theta < 90^\circ$,

Consider $\theta = 45^\circ$

$$\begin{aligned}\therefore \sin^2 \theta + \cos^2 \theta &= \sin^2 45^\circ + \cos^2 45^\circ \\ &= \left(\frac{1}{\sqrt{2}}\right)^2 + \left(\frac{1}{\sqrt{2}}\right)^2 \\ &= \frac{1}{2} + \frac{1}{2} \\ &= 1\end{aligned}$$

Solution 19b.

Since $\theta < 90^\circ$,

Consider $\theta = 45^\circ$

$$\begin{aligned}\therefore \tan^2 \theta - \frac{1}{\cos^2 \theta} &= \tan^2 45^\circ - \frac{1}{\cos^2 45^\circ} \\ &= (1)^2 - \frac{1}{\left(\frac{1}{\sqrt{2}}\right)^2} \\ &= 1 - \frac{1}{\frac{1}{2}} \\ &= 1 - 2 \\ &= -1\end{aligned}$$

Solution 20a.

$$\sqrt{3} \sec 2\theta = 2$$

$$\Rightarrow \sec 2\theta = \frac{2}{\sqrt{3}}$$

$$\Rightarrow \sec 2\theta = \sec 30^\circ$$

$$\Rightarrow 2\theta = 30^\circ$$

$$\Rightarrow \theta = 15^\circ$$

Solution 20b.

$$\sqrt{3} \sec 2\theta = 2$$

$$\Rightarrow \sec 2\theta = \frac{2}{\sqrt{3}}$$

$$\Rightarrow \sec 2\theta = \sec 30^\circ$$

$$\Rightarrow 2\theta = 30^\circ$$

$$\Rightarrow \theta = 15^\circ$$

$$\therefore \cos 3\theta = \cos 3 \times 15^\circ = \cos 45^\circ = \frac{1}{\sqrt{2}}$$

Solution 20c.

$$\sqrt{3} \sec 2\theta = 2$$

$$\Rightarrow \sec 2\theta = \frac{2}{\sqrt{3}}$$

$$\Rightarrow \sec 2\theta = \sec 30^\circ$$

$$\Rightarrow 2\theta = 30^\circ$$

$$\Rightarrow \theta = 15^\circ$$

$$\begin{aligned} \therefore \cos^2(30^\circ + \theta) + \sin^2(45^\circ - \theta) &= \cos^2(30^\circ + 15^\circ) + \sin^2(45^\circ - 15^\circ) \\ &= \cos^2 45^\circ + \sin^2 30^\circ \\ &= \left(\frac{1}{\sqrt{2}}\right)^2 + \left(\frac{1}{2}\right)^2 \\ &= \frac{1}{2} + \frac{1}{4} \\ &= \frac{3}{4} \end{aligned}$$

Solution 21.

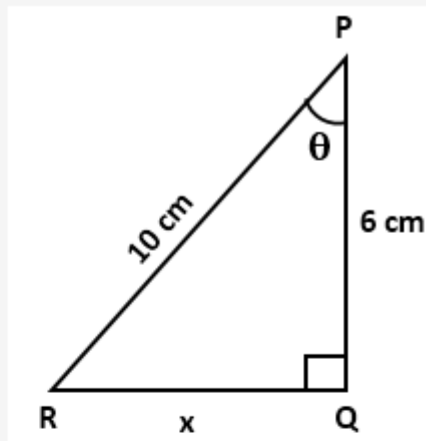

a. $\cos \theta = \frac{\text{Base}}{\text{Hypotenuse}}$
 $\Rightarrow \cos \theta = \frac{PQ}{PR} = \frac{6}{10} = \frac{3}{5}$

b. $\sin^2 \theta + \cos^2 \theta = 1$
 $\Rightarrow \sin^2 \theta + \left(\frac{3}{5}\right)^2 = 1$

$$\Rightarrow \sin^2 \theta + \frac{9}{25} = 1$$

$$\Rightarrow \sin^2 \theta = 1 - \frac{9}{25} = \frac{16}{25}$$

$$\Rightarrow \sin \theta = \frac{4}{5}$$

$$\therefore \sin^2 \theta - \cos^2 \theta = \frac{16}{25} - \frac{9}{25} = \frac{7}{25}$$

c. $\tan \theta = \frac{\sin \theta}{\cos \theta} = \frac{\frac{4}{5}}{\frac{3}{5}} = \frac{4}{3}$

But, $\tan \theta = \frac{\text{Perpendicular}}{\text{Base}} = \frac{RQ}{PQ}$

$$\Rightarrow \frac{RQ}{PQ} = \frac{4}{3}$$

$$\Rightarrow \frac{RQ}{6} = \frac{4}{3}$$

$$\Rightarrow RQ = \frac{4 \times 6}{3} = 8 \text{ cm}$$

Solution 22.

$$\sqrt{\frac{1 - \sin^2 60^\circ}{1 + \sin^2 60^\circ}} = \sqrt{\frac{1 - \left(\frac{\sqrt{3}}{2}\right)^2}{1 + \left(\frac{\sqrt{3}}{2}\right)^2}} = \sqrt{\frac{1 - \frac{3}{4}}{1 + \frac{3}{4}}} = \sqrt{\frac{\frac{1}{4}}{\frac{7}{4}}} = \sqrt{\frac{1}{7}} = \frac{1}{\sqrt{7}}$$

$$3 \tan^2 \theta - 1 = 0$$

$$\Rightarrow 3 \tan^2 \theta = 1$$

$$\Rightarrow \tan^2 \theta = \frac{1}{3}$$

$$\Rightarrow \tan \theta = \frac{1}{\sqrt{3}}$$

$$\Rightarrow \tan \theta = \tan 30^\circ$$

$$\Rightarrow \theta = 30^\circ$$

$$\text{a. } \cos 2\theta = \cos 2 \times 30^\circ = \cos 60^\circ = \frac{1}{2}$$

$$\text{b. } \sin 3\theta = \sin 3 \times 30^\circ = \sin 90^\circ = 1$$

Solution 23.

$$\sin(A + B) = 1$$

$$\Rightarrow \sin(A + B) = \sin 90^\circ$$

$$\Rightarrow A + B = 90^\circ \dots\dots (i)$$

$$\cos(A - B) = 1$$

$$\Rightarrow \cos(A - B) = \cos 0^\circ$$

$$\Rightarrow A - B = 0^\circ \dots\dots\dots (ii)$$

adding (i) and (ii)

$$A + B + A - B = 90^\circ + 0^\circ$$

$$2A = 90^\circ$$

$$A = 45^\circ$$

Substituting value of A in (i)

$$A + B = 90^\circ$$

$$45^\circ + B = 90^\circ$$

$$B = 45^\circ$$

Therefore, $A = B = 45^\circ$

Solution 24.

$$\tan(A - B) = \frac{1}{\sqrt{3}}$$

$$\Rightarrow \tan(A - B) = \tan 30^\circ$$

$$\Rightarrow A - B = 30^\circ \dots\dots (i)$$

$$\tan(A + B) = \sqrt{3}$$

$$\Rightarrow \tan(A + B) = \tan 60^\circ$$

$$\Rightarrow A + B = 60^\circ \dots\dots (ii)$$

Adding (i) and (ii)

$$A - B + A + B = 30^\circ + 60^\circ$$

$$\Rightarrow 2A = 90^\circ$$

$$\Rightarrow A = 45^\circ$$

Substituting value of A in (i)

$$A - B = 30^\circ$$

$$45^\circ - B = 30^\circ$$

$$B = 15^\circ$$

Therefore, $A = 45^\circ$ and $B = 15^\circ$

Solution 25.

$$\sin(A - B) = \frac{1}{2}$$

$$\Rightarrow \sin(A - B) = \sin 30^\circ$$

$$\Rightarrow A - B = 30^\circ \dots\dots (i)$$

$$\cos(A + B) = \frac{1}{2}$$

$$\Rightarrow \cos(A + B) = \cos 60^\circ$$

$$\Rightarrow A + B = 60^\circ \dots\dots (ii)$$

Adding (i) and (ii)

$$A - B + A + B = 30^\circ + 60^\circ$$

$$\Rightarrow 2A = 90^\circ$$

$$\Rightarrow A = 45^\circ$$

Substituting value of A in (i)

$$A - B = 30^\circ$$

$$45^\circ - B = 30^\circ$$

$$B = 15^\circ$$

Therefore, $A = 45^\circ$ and $B = 15^\circ$

Solution 26.

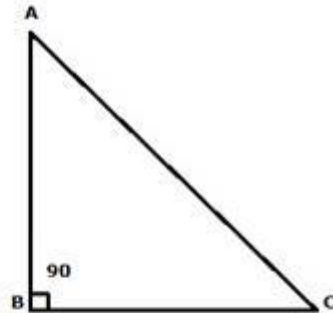

Since $\angle B$ is right angled $\Rightarrow \angle B = 90^\circ$

In $\triangle ABC$,

$$\angle A + \angle B + \angle C = 180^\circ$$

$$\text{But } \angle A = \angle C$$

$$\Rightarrow \angle A + 90^\circ + \angle A = 180^\circ$$

$$\Rightarrow 2\angle A = 90^\circ$$

$$\Rightarrow \angle A = 45^\circ = \angle C$$

(i)

$$\begin{aligned} & \sin A \cos C + \cos A \sin C \\ &= \sin 45^\circ \cos 45^\circ + \cos 45^\circ \sin 45^\circ \\ &= \frac{1}{\sqrt{2}} \times \frac{1}{\sqrt{2}} + \frac{1}{\sqrt{2}} \times \frac{1}{\sqrt{2}} \\ &= \frac{1}{2} + \frac{1}{2} \\ &= 1 \end{aligned}$$

(ii)

$$\begin{aligned} & \sin A \sin B + \cos A \cos B \\ &\Rightarrow \sin 45^\circ \sin 90^\circ + \cos 45^\circ \cos 90^\circ \\ &= \frac{1}{\sqrt{2}} \times 1 + \frac{1}{\sqrt{2}} \times 0 \\ &= \frac{1}{\sqrt{2}} \end{aligned}$$

Solution 27.

$$\text{Since } \tan A = \frac{1}{2}, \tan B = \frac{1}{3}$$

$$\tan(A + B) = \frac{\tan A + \tan B}{1 - \tan A \tan B}$$

$$\Rightarrow \tan(A + B) = \frac{\frac{1}{2} + \frac{1}{3}}{1 - \left(\frac{1}{2} \times \frac{1}{3}\right)}$$

$$\Rightarrow \tan(A + B) = \frac{\frac{5}{6}}{1 - \frac{1}{6}}$$

$$\Rightarrow \tan(A + B) = \frac{5}{5} = 1$$

$$\Rightarrow \tan(A + B) = 1$$

$$\Rightarrow \tan(A + B) = \tan 45^\circ$$

$$\Rightarrow A + B = 45^\circ$$

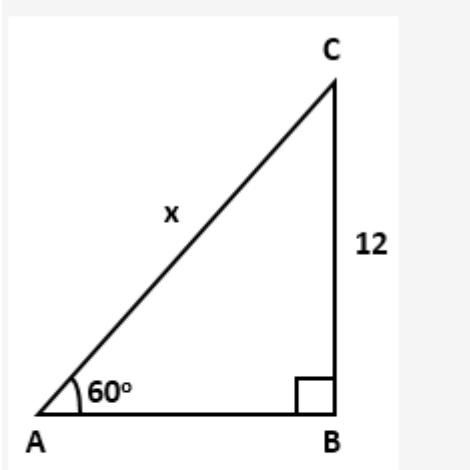
Ex No: 27.2**Solution 1a.**

From the figure, we have

$$\sin 60^\circ = \frac{BC}{AC}$$

$$\Rightarrow \frac{\sqrt{3}}{2} = \frac{12}{x}$$

$$\Rightarrow x = \frac{2 \times 12}{\sqrt{3}} = \frac{24}{\sqrt{3}} = \frac{8 \times 3}{\sqrt{3}} = 8\sqrt{3}$$

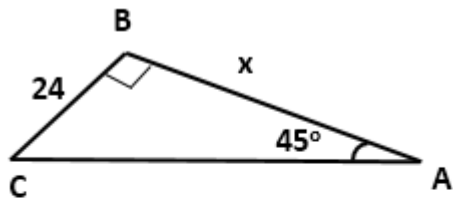
Solution 1b.

From the figure, we have

$$\tan 45^\circ = \frac{BC}{AB}$$

$$\Rightarrow 1 = \frac{24}{x}$$

$$\Rightarrow x = 24$$

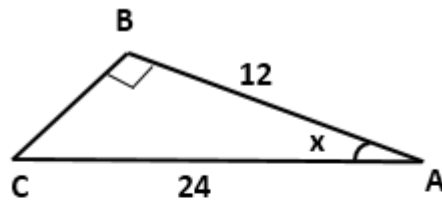
Solution 1c.

From the figure, we have

$$\cos x = \frac{AB}{AC}$$

$$\Rightarrow \cos x = \frac{12}{24}$$

$$\Rightarrow \cos x = \frac{1}{2}$$

$$\Rightarrow \cos x = \cos 60^\circ$$

$$\Rightarrow x = 60^\circ$$

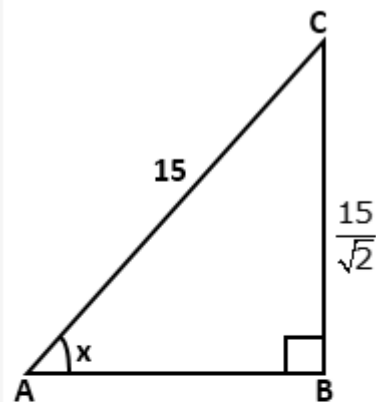
Solution 1d.

From the figure, we have

$$\sin x = \frac{BC}{AC}$$

$$\Rightarrow \sin x = \frac{\frac{15}{\sqrt{2}}}{15}$$

$$\Rightarrow \sin x = \frac{1}{\sqrt{2}}$$

$$\Rightarrow \sin x = \sin 45^\circ$$

$$\Rightarrow x = 45^\circ$$

Solution 2.

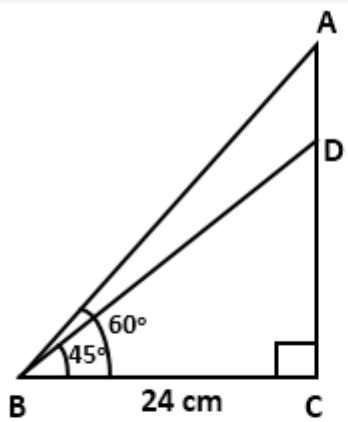

In $\triangle ABC$,

$$\tan 60^\circ = \frac{AC}{BC}$$

$$\Rightarrow \sqrt{3} = \frac{AC}{24}$$

$$\Rightarrow AC = 24\sqrt{3} \text{ cm}$$

In $\triangle DBC$,

$$\tan 45^\circ = \frac{DC}{BC}$$

$$\Rightarrow 1 = \frac{DC}{24}$$

$$\Rightarrow DC = 24 \text{ cm}$$

Now, $AC = AD + DC$

$$\Rightarrow AD = AC - DC = 24\sqrt{3} - 24 = 24(\sqrt{3} - 1) \text{ cm}$$

Solution 3.

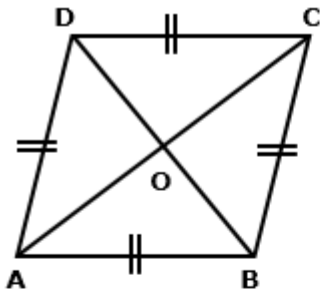

The given figure is a rhombus as all sides are equal.
We know that diagonals of a rhombus bisect each other at right angles and also bisect the angle of vertex.
Let the diagonals AC and BD intersect each other at O.

$$\Rightarrow OA = OC = \frac{1}{2}AC, \quad OB = OD = \frac{1}{2}BD, \quad \angle AOB = 90^\circ$$

$$\text{Now, } \angle BAD = 60^\circ \Rightarrow \angle OAB = \frac{1}{2}\angle BAD = 30^\circ$$

In right-angled $\triangle AOB$,

$$\sin 30^\circ = \frac{OB}{AB} \Rightarrow \frac{1}{2} = \frac{OB}{24} \Rightarrow OB = 12 \text{ cm}$$

$$\cos 30^\circ = \frac{OA}{AB} \Rightarrow \frac{\sqrt{3}}{2} = \frac{OA}{24} \Rightarrow OA = 12\sqrt{3} \text{ cm}$$

$$\therefore \text{Length of diagonal } AC = 2 \times OA = 2 \times 12\sqrt{3} = 24\sqrt{3} \text{ cm}$$

$$\text{And, length of diagonal } BD = 2 \times OB = 2 \times 12 = 24 \text{ cm}$$

Solution 4.

Construction: Draw $DP \perp AB$ and $CM \perp AB$

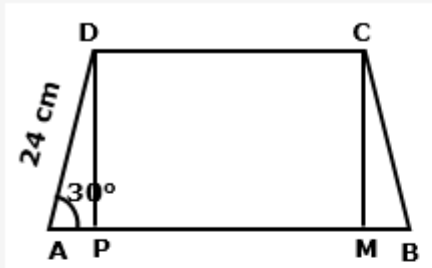

a. In right $\triangle ADP$,

$$\cos 30^\circ = \frac{AP}{AD}$$

$$\Rightarrow \frac{\sqrt{3}}{2} = \frac{AP}{24}$$

$$\Rightarrow AP = 12\sqrt{3} \text{ cm}$$

Similarly, from right $\triangle BCM$, we have $MB = 12\sqrt{3} \text{ cm}$

Now, in rectangle $PMCD$, we have $CD = PM = 24 \text{ cm}$

$$\therefore \text{Length of } AB = AP + PM + MB = 12\sqrt{3} + 24 + 12\sqrt{3} = 24(\sqrt{3} + 1) \text{ cm}$$

b. In right $\triangle ADP$,

$$\sin 30^\circ = \frac{PD}{AD}$$

$$\Rightarrow \frac{1}{2} = \frac{PD}{24}$$

$$\Rightarrow PD = 12 \text{ cm}$$

Similarly, from right $\triangle BCM$, we have $MB = 12\sqrt{3} \text{ cm}$

Now, in rectangle $PMCD$, we have $CD = PM = 24 \text{ cm}$

$$\therefore \text{Length of } AB = AP + PM + MB = 12\sqrt{3} + 24 + 12\sqrt{3} = 24(\sqrt{3} + 1) \text{ cm}$$

Solution 5.

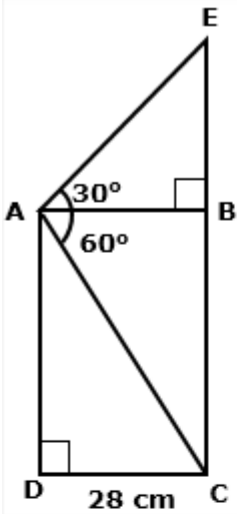

$$CD = 28 \text{ cm}$$

$$\Rightarrow AB = 28 \text{ cm}$$

In right $\triangle ABE$,

$$\tan 30^\circ = \frac{BE}{AB}$$

$$\Rightarrow \frac{1}{\sqrt{3}} = \frac{BE}{28}$$

$$\Rightarrow BE = \frac{28}{\sqrt{3}}$$

In right $\triangle ABC$,

$$\tan 60^\circ = \frac{CB}{AB}$$

$$\Rightarrow \sqrt{3} = \frac{CB}{28}$$

$$\Rightarrow CB = 28\sqrt{3}$$

$$\therefore \text{Length of EC} = CB + BE = 28\sqrt{3} + \frac{28}{\sqrt{3}} = \frac{84 + 28}{\sqrt{3}} = \frac{112}{\sqrt{3}}$$

Solution 6.

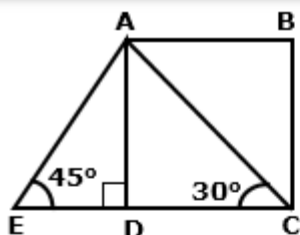

a. In right $\triangle ADC$,

$$\tan 30^\circ = \frac{AD}{DC}$$

$$\Rightarrow \frac{1}{\sqrt{3}} = \frac{1.5}{DC}$$

$$\Rightarrow DC = 1.5\sqrt{3}$$

Since $AB \parallel DC$ and $AD \perp EC$, $ABCD$ is a parallelogram and hence opposite sides are equal.

$$\Rightarrow AB = DC = 1.5\sqrt{3} \text{ cm}$$

b. In right $\triangle ADC$,

$$\sin 30^\circ = \frac{AD}{AC}$$

$$\Rightarrow \frac{1}{2} = \frac{1.5}{AC}$$

$$\Rightarrow AC = 2 \times 1.5 = 3 \text{ cm}$$

c. In right $\triangle ADE$,

$$\sin 45^\circ = \frac{AD}{AE}$$

$$\Rightarrow \frac{1}{\sqrt{2}} = \frac{1.5}{AE}$$

$$\Rightarrow AE = 1.5\sqrt{2} \text{ cm}$$

Solution 7.

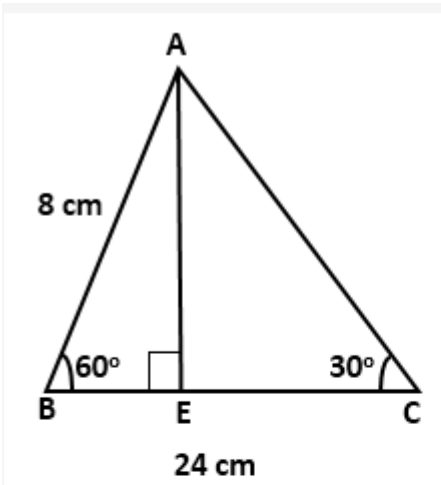

a. In right $\triangle AEB$,

$$\sin 60^\circ = \frac{AE}{AB}$$

$$\Rightarrow \frac{\sqrt{3}}{2} = \frac{AE}{8}$$

$$\Rightarrow AE = 4\sqrt{3} \text{ cm}$$

$$\text{Now, } BE^2 = AB^2 - AE^2 = 8^2 - (4\sqrt{3})^2 = 64 - 48 = 16$$

$$\Rightarrow BE = 4 \text{ cm}$$

b. $EC = BC - BE = 24 - 4 = 20 \text{ cm}$

Now, in right $\triangle AEC$,

$$AC^2 = AE^2 + EC^2 = (4\sqrt{3})^2 + 20^2 = 48 + 400 = 448$$

$$\Rightarrow AC = 8\sqrt{7} \text{ cm}$$

Solution 8.

a. In right $\triangle ABC$,

$$\tan 30^\circ = \frac{AB}{BC}$$

$$\Rightarrow \frac{1}{\sqrt{3}} = \frac{10}{BC}$$

$$\Rightarrow BC = 10\sqrt{3} \text{ cm}$$

b. In $\triangle ABC$, $\angle C = 30^\circ$ and $\angle B = 90^\circ$

$$\Rightarrow \angle A = 60^\circ$$

Now, in $\triangle ABD$,

$$\cos 60^\circ = \frac{AD}{AB}$$

$$\Rightarrow \frac{1}{2} = \frac{AD}{10}$$

$$\Rightarrow AD = 5 \text{ cm}$$

c. In $\triangle ABC$,

$$AC^2 = AB^2 + BC^2 = 10^2 + (10\sqrt{3})^2 = 100 + 300 = 400 \text{ cm}^2$$

$$\Rightarrow AC = 20 \text{ cm}$$

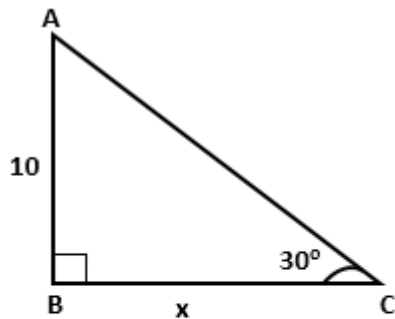
Solution 9a.

In right $\triangle ABC$,

$$\tan 30^\circ = \frac{AB}{BC}$$

$$\Rightarrow \frac{1}{\sqrt{3}} = \frac{10}{x}$$

$$\Rightarrow x = 10\sqrt{3} \text{ cm}$$

Solution 9b.

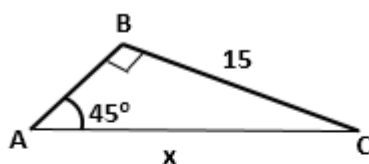

In right $\triangle ABC$,

$$\sin 45^\circ = \frac{BC}{AC}$$

$$\Rightarrow \frac{1}{\sqrt{2}} = \frac{15}{x}$$

$$\Rightarrow x = 15\sqrt{2} \text{ cm}$$

Solution 9c.

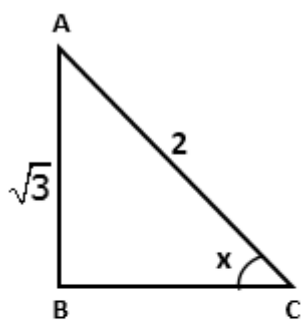

In right $\triangle ABC$,

$$\sin x = \frac{AB}{AC}$$

$$\Rightarrow \sin x = \frac{\sqrt{3}}{2}$$

$$\Rightarrow \sin x = \sin 60^\circ$$

$$\Rightarrow x = 60^\circ$$

Solution 9d.

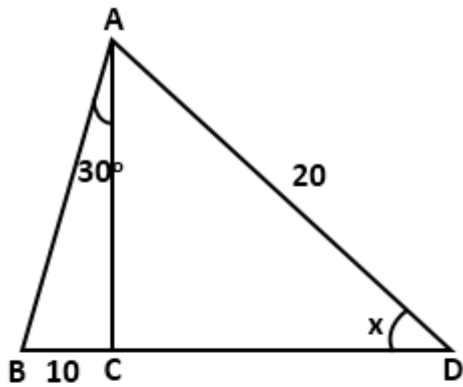

In right $\triangle ACB$,

$$\tan 30^\circ = \frac{BC}{AC}$$

$$\Rightarrow \frac{1}{\sqrt{3}} = \frac{10}{AC}$$

$$\Rightarrow AC = 10\sqrt{3} \text{ cm}$$

Now, in right $\triangle ACD$,

$$\sin x = \frac{AC}{AD}$$

$$\Rightarrow \sin x = \frac{10\sqrt{3}}{20}$$

$$\Rightarrow \sin x = \frac{\sqrt{3}}{2}$$

$$\Rightarrow \sin x = \sin 60^\circ$$

$$\Rightarrow x = 60^\circ$$

Solution 9e.

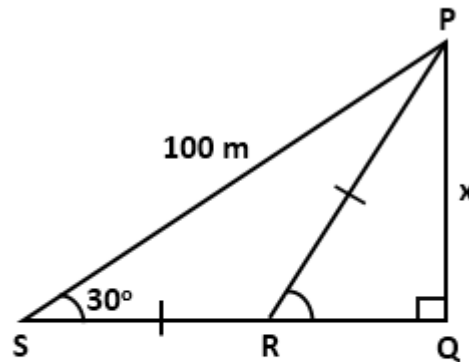

In right $\triangle PQS$,

$$\sin 30^\circ = \frac{PQ}{PS}$$

$$\Rightarrow \frac{1}{2} = \frac{x}{100}$$

$$\Rightarrow x = 50\text{ m}$$

Solution 9f.

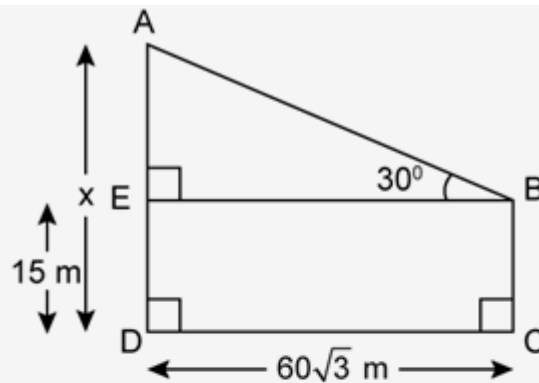

$BEDC$ is a rectangle.

$$\Rightarrow BE = DC = 60\sqrt{3}\text{ m}$$

In right $\triangle AEB$,

$$\tan 30^\circ = \frac{AE}{BE}$$

$$\Rightarrow \frac{1}{\sqrt{3}} = \frac{AE}{60\sqrt{3}}$$

$$\Rightarrow AE = 60\text{ m}$$

$$\text{Now, } x = AD = AE + ED = 60 + 15 = 75\text{ m}$$

Solution 10a.

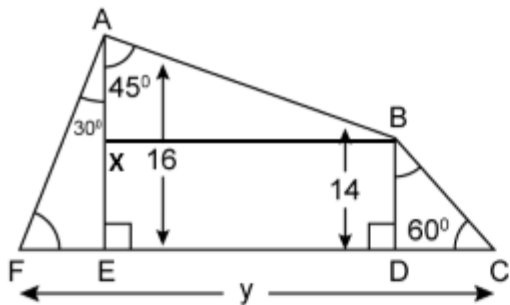

In right $\triangle AEF$,

$$\tan 30^\circ = \frac{FE}{AE}$$

$$\Rightarrow \frac{1}{\sqrt{3}} = \frac{FE}{16}$$

$$\Rightarrow FE = \frac{16}{\sqrt{3}}$$

In right $\triangle BDC$,

$$\tan 60^\circ = \frac{BD}{DC}$$

$$\Rightarrow \sqrt{3} = \frac{14}{DC}$$

$$\Rightarrow DC = \frac{14}{\sqrt{3}}$$

In right $\triangle AXB$,

$$\tan 45^\circ = \frac{BX}{AX}$$

$$\Rightarrow 1 = \frac{BX}{2}$$

$$\Rightarrow BX = 2$$

$$\Rightarrow ED = BX = 2$$

$$\text{Now, } y = FC = FE + ED + DC = \frac{16}{\sqrt{3}} + \frac{14}{\sqrt{3}} + 2 = \frac{30 + 2\sqrt{3}}{\sqrt{3}} = \frac{30 + 3.464}{1.732} = 19.32$$

Solution 10b.

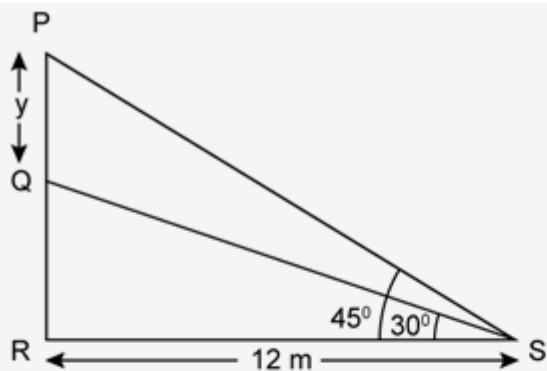

In right $\triangle PRS$,

$$\tan 45^\circ = \frac{PR}{RS}$$

$$\Rightarrow 1 = \frac{PR}{12}$$

$$\Rightarrow PR = 12$$

In right $\triangle QRS$,

$$\tan 30^\circ = \frac{QR}{RS}$$

$$\Rightarrow \frac{1}{\sqrt{3}} = \frac{QR}{12}$$

$$\Rightarrow QR = \frac{12}{\sqrt{3}}$$

$$\text{Now, } y = PQ = PR - QR = 12 - \frac{12}{\sqrt{3}} = 12 - \frac{12}{1.732} = 12 - 6.93 = 5.07$$

Solution 11.

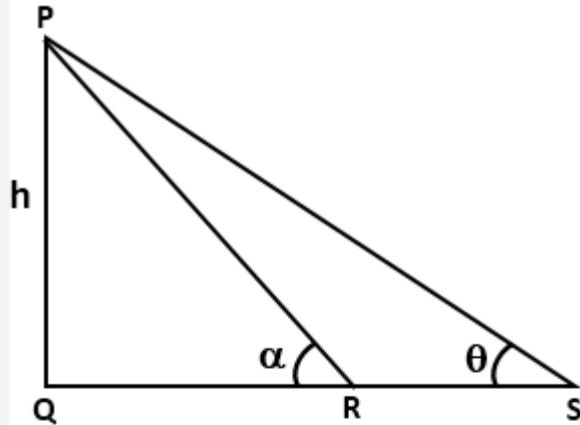

$$\tan \theta = \frac{PQ}{QS}$$

$$\Rightarrow \frac{5}{13} = \frac{h}{QS}$$

$$\Rightarrow 5 \times QS = 13h$$

$$\Rightarrow 5(QR + RS) = 13h$$

$$\Rightarrow 5(QR + 12) = 13h$$

$$\Rightarrow QR + 12 = \frac{13h}{5} \quad \dots(i)$$

$$\tan \alpha = \frac{PQ}{QR}$$

$$\Rightarrow \frac{3}{5} = \frac{h}{QR}$$

$$\Rightarrow 3 \times QR = 5h$$

$$\Rightarrow QR = \frac{5h}{3} \quad \dots(ii)$$

Substituting (ii) in (i), we have

$$\frac{5h}{3} + 12 = \frac{13h}{5}$$

$$\Rightarrow \frac{13h}{5} - \frac{5h}{3} = 12$$

$$\Rightarrow \frac{39h - 25h}{15} = 12$$

$$\Rightarrow 14h = 180$$

$$\Rightarrow h = 12.86 \text{ m}$$

Solution 12a.

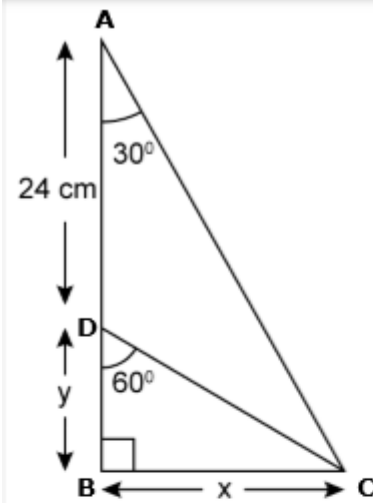

In right $\triangle ABC$,

$$\tan 30^\circ = \frac{BC}{AB}$$

$$\Rightarrow \frac{1}{\sqrt{3}} = \frac{x}{24 + y} \quad \dots(i)$$

In right $\triangle DBC$,

$$\tan 60^\circ = \frac{BC}{DB}$$

$$\Rightarrow \sqrt{3} = \frac{x}{y}$$

$$\Rightarrow x = \sqrt{3}y$$

Substituting the value of x in (i), we get

$$\frac{1}{\sqrt{3}} = \frac{\sqrt{3}y}{24 + y}$$

$$\Rightarrow 24 + y = 3y$$

$$\Rightarrow 2y = 24$$

$$\Rightarrow y = 12 \text{ cm}$$

$$\Rightarrow x = \sqrt{3} \times 12 = 12\sqrt{3} \text{ cm}$$

Solution 12b.

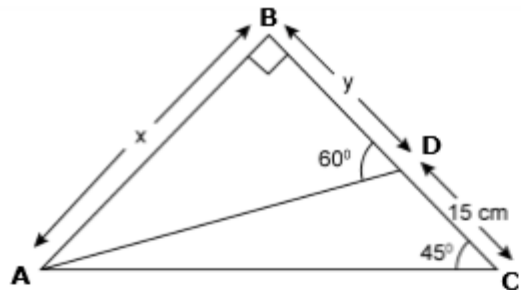

In right $\triangle ABC$,

$$\tan 45^\circ = \frac{AB}{BC}$$

$$\Rightarrow 1 = \frac{x}{15 + y}$$

$$\Rightarrow x = 15 + y \quad \dots(i)$$

In right $\triangle ABD$,

$$\tan 60^\circ = \frac{AB}{DB}$$

$$\Rightarrow \sqrt{3} = \frac{x}{y}$$

$$\Rightarrow \sqrt{3} = \frac{15 + y}{y} \quad \dots[\text{From (i)}]$$

$$\Rightarrow \sqrt{3}y = 15 + y$$

$$\Rightarrow \sqrt{3}y - y = 15$$

$$\Rightarrow y(\sqrt{3} - 1) = 15$$

$$\Rightarrow y = \frac{15}{\sqrt{3} - 1}$$

$$\Rightarrow y = \frac{15}{\sqrt{3} - 1} \times \frac{\sqrt{3} + 1}{\sqrt{3} + 1} = \frac{15(\sqrt{3} + 1)}{3 - 1} = \frac{15(\sqrt{3} + 1)}{2} \text{ cm}$$

$$\Rightarrow x = 15 + \frac{15(\sqrt{3} + 1)}{2} = \frac{30 + 15(\sqrt{3} + 1)}{2} = \frac{15(2 + \sqrt{3} + 1)}{2} = \frac{15(3 + \sqrt{3})}{2} = \frac{15\sqrt{3}(\sqrt{3} + 1)}{2}$$

Solution 13.

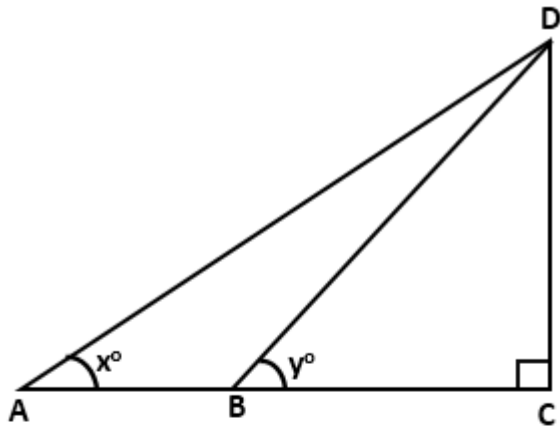

$$\begin{aligned}\tan x &= \frac{CD}{AC} \\ \Rightarrow \frac{5}{12} &= \frac{CD}{AC} \\ \Rightarrow 5 \times AC &= 12 \times CD \\ \Rightarrow 5(AB + BC) &= 12CD \\ \Rightarrow 5(48 + BC) &= 12CD \\ \Rightarrow 48 + BC &= \frac{12CD}{5} \quad \dots(i)\end{aligned}$$

$$\begin{aligned}\tan y &= \frac{CD}{BC} \\ \Rightarrow \frac{3}{4} &= \frac{CD}{BC} \\ \Rightarrow 3BC &= 4CD \\ \Rightarrow BC &= \frac{4CD}{3} \quad \dots(ii)\end{aligned}$$

Substituting (ii) in (i), we have

$$\begin{aligned}48 + \frac{4CD}{3} &= \frac{12CD}{5} \\ \Rightarrow \frac{12CD}{5} - \frac{4CD}{3} &= 48 \\ \Rightarrow \frac{36CD - 20CD}{15} &= 48 \\ \Rightarrow 16CD &= 720 \\ \Rightarrow CD &= 45 \text{ m}\end{aligned}$$

Solution 17.

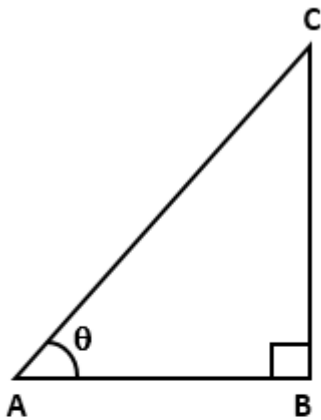

a. Given, $AB = \sqrt{3} \times BC$

$$\Rightarrow \frac{AB}{BC} = \sqrt{3}$$

$$\Rightarrow \cot \theta = \sqrt{3}$$

$$\Rightarrow \cot \theta = \cot 30^\circ$$

$$\Rightarrow \theta = 30^\circ$$

b. Given, $BC = \sqrt{3} \times AB$

$$\Rightarrow \frac{BC}{AB} = \sqrt{3}$$

$$\Rightarrow \tan \theta = \sqrt{3}$$

$$\Rightarrow \tan \theta = \tan 60^\circ$$

$$\Rightarrow \theta = 60^\circ$$

Solution 18.

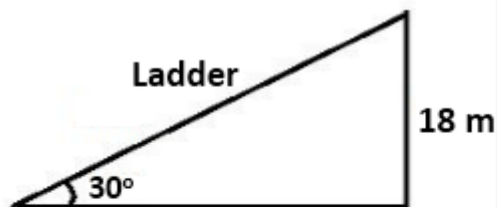

Suppose the length of ladder is x m.

From the figure, we have

$$\frac{18}{x} = \sin 30^\circ \quad \dots \left[\because \sin = \frac{\text{Perpendicular}}{\text{Hypotenuse}} \right]$$

$$\Rightarrow \frac{18}{x} = \frac{1}{2}$$

$$\Rightarrow x = 36$$

Thus, the length of ladder is 36 m.

Solution 19.

Consider the following figure,

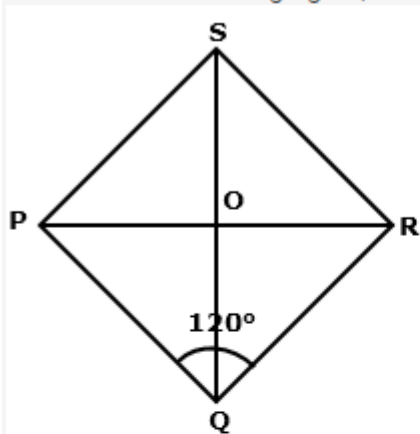

Perimeter of rhombus = 100 cm

$$\Rightarrow PQ = QR = RS = SP = \frac{100}{4} = 25 \text{ cm}$$

Diagonals of a rhombus bisect each other at right angles.

$$\Rightarrow PO = OR \text{ and } QO = OS$$

$$\text{And, } \angle POQ = \angle ROQ = \angle ROS = \angle POS = 90^\circ$$

Also, diagonals bisect the angle at vertex.

$$\Rightarrow \angle PQO = \frac{1}{2} \angle PQR = \frac{1}{2} \times 120^\circ = 60^\circ$$

Now, in right $\triangle POR$,

$$\sin(\angle PQO) = \frac{OP}{PQ}$$

$$\Rightarrow \sin 60^\circ = \frac{OP}{25}$$

$$\Rightarrow \frac{\sqrt{3}}{2} = \frac{OP}{25}$$

$$\Rightarrow OP = \frac{25\sqrt{3}}{2}$$

$$\therefore PR = 2 \times OP = 2 \times \frac{25\sqrt{3}}{2} = 25\sqrt{3} \text{ cm}$$

$$\text{Also, } \cos(\angle PQO) = \frac{OQ}{PQ}$$

$$\Rightarrow \cos 60^\circ = \frac{OQ}{25}$$

$$\Rightarrow \frac{1}{2} = \frac{OQ}{25}$$

$$\Rightarrow OQ = \frac{25}{2}$$

$$\therefore SQ = 2 \times OQ = 2 \times \frac{25}{2} = 25 \text{ cm}$$

Solution 20.

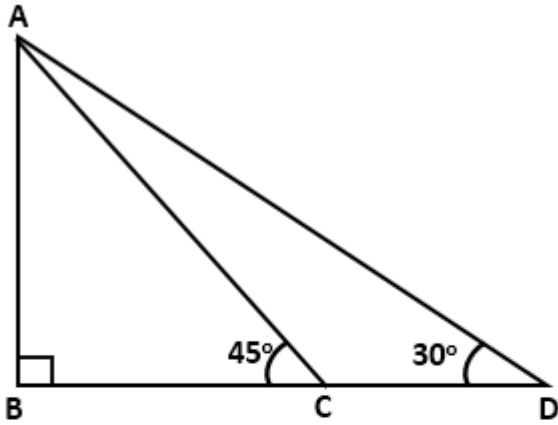

In right $\triangle ABC$,

$$\tan 45^\circ = \frac{AB}{BC}$$

$$\Rightarrow 1 = \frac{24}{BC}$$

$$\Rightarrow BC = 24 \text{ m}$$

In right $\triangle ABD$,

$$\tan 30^\circ = \frac{AB}{BD}$$

$$\Rightarrow \frac{1}{\sqrt{3}} = \frac{24}{BD}$$

$$\Rightarrow BD = 24\sqrt{3} \text{ m}$$

$$\text{Now, } CD = BD - BC = 24\sqrt{3} - 24 = 24(\sqrt{3} - 1) \text{ m}$$

Solution 21.

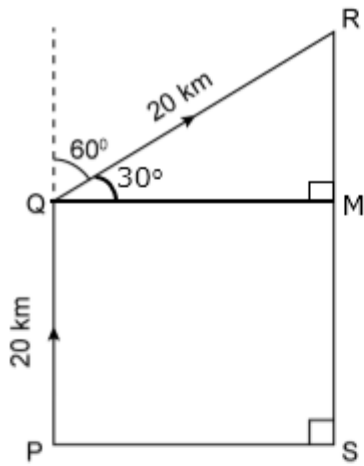

a. In right $\triangle RMQ$,

$$\sin 30^\circ = \frac{RM}{RQ}$$

$$\Rightarrow \frac{1}{2} = \frac{RM}{20}$$

$$\Rightarrow RM = 10 \text{ km}$$

\therefore The height of the rocket when it is at point R

$$= RS$$

$$= RM + MS$$

$$= 10 \text{ km} + 20 \text{ km}$$

$$= 30 \text{ km}$$

b. In right $\triangle RMQ$,

$$\cos 30^\circ = \frac{QM}{RQ}$$

$$\Rightarrow \frac{\sqrt{3}}{2} = \frac{QM}{20}$$

$$\Rightarrow QM = 10\sqrt{3} \text{ km}$$

\therefore The horizontal distance of point S from P

$$= PS$$

$$= QM$$

$$= 10\sqrt{3} \text{ km}$$

Ex No: 27.3**Solution 1a.**

$$\frac{\sin 62^\circ}{\cos 28^\circ} = \frac{\sin(90^\circ - 28^\circ)}{\cos 28^\circ} = \frac{\cos 28^\circ}{\cos 28^\circ} = 1$$

Solution 1b.

$$\frac{\sec 34^\circ}{\operatorname{cosec} 56^\circ} = \frac{\sec(90^\circ - 56^\circ)}{\operatorname{cosec} 56^\circ} = \frac{\operatorname{cosec} 56^\circ}{\operatorname{cosec} 56^\circ} = 1$$

Solution 1c.

$$\frac{\tan 12^\circ}{\cot 78^\circ} = \frac{\tan(90^\circ - 78^\circ)}{\cot 78^\circ} = \frac{\cot 78^\circ}{\cot 78^\circ} = 1$$

Solution 1d.

$$\begin{aligned} & \frac{\sin 25^\circ \cos 43^\circ}{\sin 47^\circ \cos 65^\circ} \\ &= \frac{\sin(90^\circ - 65^\circ) \cos(90^\circ - 47^\circ)}{\sin 47^\circ \cos 65^\circ} \\ &= \frac{\cos 65^\circ \sin 47^\circ}{\sin 47^\circ \cos 65^\circ} \\ &= 1 \end{aligned}$$

Solution 1e.

$$\begin{aligned} & \frac{\sec 32^\circ \cot 26^\circ}{\tan 64^\circ \operatorname{cosec} 58^\circ} \\ &= \frac{\sec(90^\circ - 58^\circ) \cot(90^\circ - 64^\circ)}{\tan 64^\circ \operatorname{cosec} 58^\circ} \\ &= \frac{\operatorname{cosec} 58^\circ \cot 64^\circ}{\tan 64^\circ \operatorname{cosec} 58^\circ} \\ &= 1 \end{aligned}$$

Solution 1f.

$$\begin{aligned} & \frac{\cos 34^\circ \cos 33^\circ}{\sin 57^\circ \sin 56^\circ} \\ &= \frac{\cos(90^\circ - 56^\circ) \cos(90^\circ - 57^\circ)}{\sin 57^\circ \sin 56^\circ} \\ &= \frac{\sin 56^\circ \sin 57^\circ}{\sin 57^\circ \sin 56^\circ} \\ &= 1 \end{aligned}$$

Solution 2a.

$$\begin{aligned} & \sin 31^\circ - \cos 59^\circ \\ &= \sin(90^\circ - 59^\circ) - \cos 59^\circ \\ &= \cos 59^\circ - \cos 59^\circ \\ &= 0 \end{aligned}$$

Solution 2b.

$$\begin{aligned} & \cot 27^\circ - \tan 63^\circ \\ &= \cot(90^\circ - 63^\circ) - \tan 63^\circ \\ &= \tan 63^\circ - \tan 63^\circ \\ &= 0 \end{aligned}$$

Solution 2c.

$$\begin{aligned} & \operatorname{cosec} 54^\circ - \sec 36^\circ \\ &= \operatorname{cosec}(90^\circ - 36^\circ) - \sec 36^\circ \\ &= \sec 36^\circ - \sec 36^\circ \\ &= 0 \end{aligned}$$

Solution 2d.

$$\begin{aligned} & \sin 28^\circ \sec 62^\circ + \tan 49^\circ \tan 41^\circ \\ &= \sin 28^\circ \sec(90^\circ - 28^\circ) + \tan 49^\circ \tan(90^\circ - 49^\circ) \\ &= \sin 28^\circ \operatorname{cosec} 28^\circ + \tan 49^\circ \cot 49^\circ \\ &= \sin 28^\circ \times \frac{1}{\sin 28^\circ} + \tan 49^\circ \times \frac{1}{\tan 49^\circ} \\ &= 1 + 1 \\ &= 2 \end{aligned}$$

Solution 2e.

$$\begin{aligned} & \sec 16^\circ \tan 28^\circ - \cot 62^\circ \operatorname{cosec} 74^\circ \\ &= \sec(90^\circ - 74^\circ) \tan(90^\circ - 62^\circ) - \cot 62^\circ \operatorname{cosec} 74^\circ \\ &= \operatorname{cosec} 74^\circ \cot 62^\circ - \cot 62^\circ \operatorname{cosec} 74^\circ \\ &= 0 \end{aligned}$$

Solution 2f.

$$\begin{aligned} & \sin 22^\circ \cos 44^\circ - \sin 46^\circ \cos 68^\circ \\ &= \sin(90^\circ - 68^\circ) \cos(90^\circ - 46^\circ) - \sin 46^\circ \cos 68^\circ \\ &= \cos 68^\circ \sin 46^\circ - \sin 46^\circ \cos 68^\circ \\ &= 0 \end{aligned}$$

Solution 3a.

$$\begin{aligned} & \frac{\sin 36^\circ}{\cos 54^\circ} + \frac{\sec 31^\circ}{\operatorname{cosec} 59^\circ} \\ &= \frac{\sin(90^\circ - 54^\circ)}{\cos 54^\circ} + \frac{\sec(90^\circ - 59^\circ)}{\operatorname{cosec} 59^\circ} \\ &= \frac{\cos 54^\circ}{\cos 54^\circ} + \frac{\operatorname{cosec} 59^\circ}{\operatorname{cosec} 59^\circ} \\ &= 1 + 1 \\ &= 2 \end{aligned}$$

Solution 3b.

$$\begin{aligned} & \frac{\tan 42^\circ}{\cot 48^\circ} - \frac{\cos 33^\circ}{\sin 57^\circ} \\ &= \frac{\tan(90^\circ - 48^\circ)}{\cot 48^\circ} - \frac{\cos(90^\circ - 57^\circ)}{\sin 57^\circ} \\ &= \frac{\cot 48^\circ}{\cot 48^\circ} - \frac{\sin 57^\circ}{\sin 57^\circ} \\ &= 1 - 1 \\ &= 0 \end{aligned}$$

Solution 3c.

$$\begin{aligned} & \frac{2 \sin 28^\circ}{\cos 62^\circ} + \frac{3 \cot 49^\circ}{\tan 41^\circ} \\ &= \frac{2 \sin (90^\circ - 62^\circ)}{\cos 62^\circ} + \frac{3 \cot (90^\circ - 41^\circ)}{\tan 41^\circ} \\ &= \frac{2 \cos 62^\circ}{\cos 62^\circ} + \frac{3 \tan 41^\circ}{\tan 41^\circ} \\ &= 2 + 3 \\ &= 5 \end{aligned}$$

Solution 3d.

$$\begin{aligned} & \frac{5 \sec 68^\circ}{\operatorname{cosec} 22^\circ} + \frac{3 \sin 52^\circ \sec 38^\circ}{\cot 51^\circ \cot 39^\circ} \\ &= \frac{5 \sec (90^\circ - 22^\circ)}{\operatorname{cosec} 22^\circ} + \frac{3 \sin 52^\circ \sec (90^\circ - 52^\circ)}{\cot 51^\circ \cot (90^\circ - 51^\circ)} \\ &= \frac{5 \operatorname{cosec} 22^\circ}{\operatorname{cosec} 22^\circ} + \frac{3 \sin 52^\circ \operatorname{cosec} 52^\circ}{\cot 51^\circ \tan 51^\circ} \\ &= 5 + \frac{3 \sin 52^\circ \times \frac{1}{\sin 52^\circ}}{\cot 51^\circ \times \frac{1}{\cot 51^\circ}} \\ &= 5 + \frac{3}{1} \\ &= 5 + 3 \\ &= 8 \end{aligned}$$

Solution 4a.

$$\begin{aligned} & \sin 65^\circ + \cot 59^\circ \\ &= \sin (90^\circ - 25^\circ) + \cot (90^\circ - 31^\circ) \\ &= \cos 25^\circ + \tan 31^\circ \end{aligned}$$

Solution 4b.

$$\begin{aligned} & \cos 72^\circ - \cos 88^\circ \\ &= \cos (90^\circ - 18^\circ) - \cos (90^\circ - 2^\circ) \\ &= \sin 18^\circ - \sin 2^\circ \end{aligned}$$

Solution 4c.

$$\begin{aligned}
& \operatorname{cosec} 64^\circ + \sec 70^\circ \\
&= \operatorname{cosec} (90^\circ - 26^\circ) + \sec (90^\circ - 20^\circ) \\
&= \sec 26^\circ + \operatorname{cosec} 20^\circ
\end{aligned}$$

Solution 4d.

$$\begin{aligned}
& \tan 77^\circ - \cot 63^\circ + \sin 57^\circ \\
&= \tan (90^\circ - 13^\circ) - \cot (90^\circ - 27^\circ) + \sin (90^\circ - 33^\circ) \\
&= \cot 13^\circ - \tan 27^\circ + \cos 33^\circ
\end{aligned}$$

Solution 4e.

$$\begin{aligned}
& \sin 53^\circ + \sec 66^\circ - \sin 50^\circ \\
&= \sin (90^\circ - 37^\circ) + \sec (90^\circ - 24^\circ) - \sin (90^\circ - 40^\circ) \\
&= \cos 37^\circ + \operatorname{cosec} 24^\circ - \cos 40^\circ
\end{aligned}$$

Solution 4f.

$$\begin{aligned}
& \cos 84^\circ + \operatorname{cosec} 69^\circ - \cot 68^\circ \\
&= \cos (90^\circ - 6^\circ) + \operatorname{cosec} (90^\circ - 21^\circ) - \cot (90^\circ - 22^\circ) \\
&= \sin 6^\circ + \sec 21^\circ - \tan 22^\circ
\end{aligned}$$

Solution 5a.

$$\begin{aligned}
& \sin 35^\circ \sin 45^\circ \sec 55^\circ \sec 45^\circ \\
&= \sin (90^\circ - 55^\circ) \times \frac{1}{\sqrt{2}} \times \frac{1}{\cos 55^\circ} \times \sqrt{2} \\
&= \cos 55^\circ \times \frac{1}{\cos 55^\circ} \times \frac{1}{\sqrt{2}} \times \sqrt{2} \\
&= 1
\end{aligned}$$

Solution 5b.

$$\begin{aligned}
& \cot 20^\circ \cot 40^\circ \cot 45^\circ \cot 50^\circ \cot 70^\circ \\
&= \cot (90^\circ - 70^\circ) \times \cot (90^\circ - 50^\circ) \times 1 \times \cot 50^\circ \times \cot 70^\circ \\
&= \tan 70^\circ \times \tan 50^\circ \times \cot 50^\circ \times \cot 70^\circ \\
&= \tan 70^\circ \times \cot 70^\circ \times \tan 50^\circ \times \cot 50^\circ \\
&= \tan 70^\circ \times \frac{1}{\tan 70^\circ} \times \tan 50^\circ \times \frac{1}{\tan 50^\circ} \\
&= 1
\end{aligned}$$

Solution 5c.

$$\begin{aligned}
& \cos 39^\circ \cos 48^\circ \cos 60^\circ \operatorname{cosec} 42^\circ \operatorname{cosec} 51^\circ \\
&= \cos (90^\circ - 51^\circ) \times \cos (90^\circ - 42^\circ) \times \frac{1}{2} \times \frac{1}{\sin 42^\circ} \times \frac{1}{\sin 51^\circ} \\
&= \sin 51^\circ \times \sin 42^\circ \times \frac{1}{2} \times \frac{1}{\sin 42^\circ} \times \frac{1}{\sin 51^\circ} \\
&= \frac{1}{2}
\end{aligned}$$

Solution 5d.

$$\begin{aligned}
& \sin (35^\circ + \theta) - \cos (55^\circ - \theta) - \tan (42^\circ + \theta) + \cot (48^\circ - \theta) \\
&= \sin [90^\circ - (55^\circ - \theta)] - \cos (55^\circ - \theta) - \tan [90^\circ - (48^\circ - \theta)] + \cot (48^\circ - \theta) \\
&= \cos (55^\circ - \theta) - \cos (55^\circ - \theta) - \cot (48^\circ - \theta) + \cot (48^\circ - \theta) \\
&= 0
\end{aligned}$$

Solution 5e.

$$\begin{aligned}
& \tan (78^\circ + \theta) + \operatorname{cosec} (42^\circ + \theta) - \cot (12^\circ - \theta) - \sec (48^\circ - \theta) \\
&= \tan [90^\circ - (12^\circ - \theta)] + \operatorname{cosec} [90^\circ - (48^\circ - \theta)] - \cot (12^\circ - \theta) - \sec (48^\circ - \theta) \\
&= \cot (12^\circ - \theta) + \sec (48^\circ - \theta) - \cot (12^\circ - \theta) - \sec (48^\circ - \theta) \\
&= 0
\end{aligned}$$

Solution 5f.

$$\begin{aligned}
& \frac{3 \sin 37^\circ}{\cos 53^\circ} - \frac{5 \operatorname{cosec} 39^\circ}{\sec 51^\circ} + \frac{4 \tan 23^\circ \tan 37^\circ \tan 67^\circ \tan 53^\circ}{\cos 17^\circ \cos 67^\circ \operatorname{cosec} 73^\circ \operatorname{cosec} 23^\circ} \\
&= \frac{3 \sin (90^\circ - 53^\circ)}{\cos 53^\circ} - \frac{5 \operatorname{cosec} (90^\circ - 51^\circ)}{\sec 51^\circ} \\
&\quad + \frac{4 \tan (90^\circ - 67^\circ) \tan (90^\circ - 53^\circ) \times \frac{1}{\cot 67^\circ} \times \frac{1}{\cot 53^\circ}}{\cos (90^\circ - 73^\circ) \cos (90^\circ - 23^\circ) \times \frac{1}{\sin 73^\circ} \times \frac{1}{\sin 23^\circ}} \\
&= \frac{3 \cos 53^\circ}{\cos 53^\circ} - \frac{5 \sec 51^\circ}{\sec 51^\circ} + \frac{4 \cot 67^\circ \cot 53^\circ \times \frac{1}{\cot 67^\circ} \times \frac{1}{\cot 53^\circ}}{\sin 73^\circ \sin 23^\circ \times \frac{1}{\sin 73^\circ} \times \frac{1}{\sin 23^\circ}} \\
&= 3 - 5 + 4 \\
&= 2
\end{aligned}$$

Solution 5g.

$$\frac{\sin 0^\circ \sin 35^\circ \sin 55^\circ \sin 75^\circ}{\cos 22^\circ \cos 64^\circ \cos 68^\circ \cos 90^\circ}$$

$$= \frac{0 \times \sin 35^\circ \sin 55^\circ \sin 75^\circ}{\cos 22^\circ \cos 64^\circ \cos 68^\circ \times 0}$$

$$= 0$$

Solution 5h.

$$\frac{2 \sin 25^\circ \sin 35^\circ \sec 55^\circ \sec 65^\circ}{5 \tan 29^\circ \tan 45^\circ \tan 61^\circ} + \frac{3 \cos 20^\circ \cos 50^\circ \cot 70^\circ \cot 40^\circ}{5 \tan 20^\circ \tan 50^\circ \sin 70^\circ \sin 40^\circ}$$

$$= \frac{2 \sin (90^\circ - 65^\circ) \sin (90^\circ - 55^\circ) \sec 55^\circ \sec 65^\circ}{5 \tan (90^\circ - 61^\circ) \times 1 \times \tan 61^\circ}$$

$$+ \frac{3 \cos (90^\circ - 70^\circ) \cos (90^\circ - 40^\circ) \cot (90^\circ - 20^\circ) \cot (90^\circ - 50^\circ)}{5 \tan 20^\circ \tan 50^\circ \sin 70^\circ \sin 40^\circ}$$

$$= \frac{2 \cos 65^\circ \cos 55^\circ \times \frac{1}{\cos 55^\circ} \times \frac{1}{\sec 65^\circ}}{5 \cot 61^\circ \times 1 \times \frac{1}{\cot 61^\circ}} + \frac{3 \sin 70^\circ \sin 40^\circ \tan 20^\circ \tan 50^\circ}{5 \tan 20^\circ \tan 50^\circ \sin 70^\circ \sin 40^\circ}$$

$$= \frac{2}{5} + \frac{3}{5}$$

$$= \frac{5}{5}$$

$$= 1$$

Solution 5i.

$$\frac{3 \sin^2 40^\circ}{4 \cos^2 50^\circ} - \frac{\operatorname{cosec}^2 28^\circ}{4 \sec^2 62^\circ} + \frac{\cos 10^\circ \cos 25^\circ \cos 45^\circ \operatorname{cosec} 80^\circ}{2 \sin 15^\circ \sin 25^\circ \sin 45^\circ \sin 65^\circ \sec 75^\circ}$$

$$= \frac{3 \sin^2 (90^\circ - 50^\circ)}{4 \cos^2 50^\circ} - \frac{\operatorname{cosec}^2 (90^\circ - 62^\circ)}{4 \sec^2 62^\circ}$$

$$+ \frac{\cos (90^\circ - 80^\circ) \cos 25^\circ \times \frac{1}{\sqrt{2}} \times \frac{1}{\sin 80^\circ}}{2 \sin (90^\circ - 75^\circ) \times \frac{1}{\sqrt{2}} \times \sin (90^\circ - 25^\circ) \times \frac{1}{\cos 75^\circ}}$$

$$= \frac{3 \cos^2 50^\circ}{4 \cos^2 50^\circ} - \frac{\sec^2 62^\circ}{4 \sec^2 62^\circ} + \frac{\sin 80^\circ \times \cos 25^\circ \times \frac{1}{\sin 80^\circ}}{2 \cos 75^\circ \times \cos 25^\circ \times \frac{1}{\cos 75^\circ}}$$

$$= \frac{3}{4} - \frac{1}{4} + \frac{1}{2}$$

$$= \frac{1}{2} + \frac{1}{2}$$

$$= 1$$

Solution 5j.

$$\begin{aligned}
& \frac{5 \cot 5^\circ \cot 15^\circ \cot 25^\circ \cot 35^\circ \cot 45^\circ}{7 \tan 45^\circ \tan 55^\circ \tan 65^\circ \tan 75^\circ \tan 85^\circ} \\
& + \frac{2 \operatorname{cosec} 12^\circ \operatorname{cosec} 24^\circ \cos 78^\circ \cos 66^\circ}{7 \sin 14^\circ \sin 23^\circ \sec 76^\circ \sec 67^\circ} \\
& = \frac{5 \cot (90^\circ - 85^\circ) \cot (90^\circ - 75^\circ) \cot (90^\circ - 65^\circ) \cot (90^\circ - 55^\circ) \times 1}{7 \times 1 \times \tan 55^\circ \tan 65^\circ \tan 75^\circ \tan 85^\circ} \\
& + \frac{2 \operatorname{cosec} (90^\circ - 78^\circ) \operatorname{cosec} (90^\circ - 66^\circ) \cos 78^\circ \cos 66^\circ}{7 \sin (90^\circ - 76^\circ) \sin (90^\circ - 67^\circ) \sec 76^\circ \sec 67^\circ} \\
& = \frac{5 \tan 85^\circ \tan 75^\circ \tan 65^\circ \tan 55^\circ}{7 \times \tan 55^\circ \tan 65^\circ \tan 75^\circ \tan 85^\circ} \\
& + \frac{2 \sec 78^\circ \sec 66^\circ \times \frac{1}{\sec 78^\circ} \times \frac{1}{\sec 66^\circ}}{7 \cos 76^\circ \cos 67^\circ \times \frac{1}{\cos 76^\circ} \times \frac{1}{\cos 67^\circ}} \\
& = \frac{5}{7} + \frac{2}{7} \\
& = \frac{7}{7} \\
& = 1
\end{aligned}$$

Solution 6.

$$\begin{aligned}
\cos 3\theta &= \sin (\theta - 34^\circ) \\
\Rightarrow \sin (90^\circ - 3\theta) &= \sin (\theta - 34^\circ) \\
\Rightarrow 90^\circ - 3\theta &= \theta - 34^\circ \\
\Rightarrow 4\theta &= 124^\circ \\
\Rightarrow \theta &= 31^\circ
\end{aligned}$$

Solution 7.

$$\begin{aligned}
\tan 4\theta &= \cot (\theta + 20^\circ) \\
\Rightarrow \cot (90^\circ - 4\theta) &= \cot (\theta + 20^\circ) \\
\Rightarrow 90^\circ - 4\theta &= \theta + 20^\circ \\
\Rightarrow 5\theta &= 70^\circ \\
\Rightarrow \theta &= 14^\circ
\end{aligned}$$

Solution 8.

$$\begin{aligned}
\sec 2\theta &= \operatorname{cosec} 3\theta \\
\Rightarrow \sec 2\theta &= \sec (90^\circ - 3\theta) \\
\Rightarrow 2\theta &= 90^\circ - 3\theta \\
\Rightarrow 5\theta &= 90^\circ \\
\Rightarrow \theta &= 18^\circ
\end{aligned}$$

Solution 9.

$$\begin{aligned}\sin(\theta - 15^\circ) &= \cos(\theta - 25^\circ) \\ \Rightarrow \cos[90^\circ - (\theta - 15^\circ)] &= \cos(\theta - 25^\circ) \\ \Rightarrow 90^\circ - (\theta - 15^\circ) &= \theta - 25^\circ \\ \Rightarrow 105^\circ - \theta &= \theta - 25^\circ \\ \Rightarrow 2\theta &= 130^\circ \\ \Rightarrow \theta &= 65^\circ\end{aligned}$$

Solution 10.

Since A, B and C are interior angles of $\triangle ABC$,

$$A + B + C = 180^\circ$$

$$\Rightarrow A + B = 180^\circ - C$$

Now,

$$\begin{aligned}\text{L.H.S.} &= \sin\left(\frac{A+B}{2}\right) \\ &= \sin\left(\frac{180^\circ - C}{2}\right) \\ &= \sin\left(90^\circ - \frac{C}{2}\right) \\ &= \cos\frac{C}{2} \\ &= \text{R.H.S.}\end{aligned}$$

Solution 11.

since P, Q and R are the interior angles of $\triangle PQR$,

$$P + Q + R = 180^\circ$$

$$\Rightarrow Q + R = 180^\circ - P$$

Now,

$$\begin{aligned}\text{L.H.S.} &= \cot\left(\frac{Q+R}{2}\right) \\ &= \cot\left(\frac{180^\circ - P}{2}\right) \\ &= \cot\left(90^\circ - \frac{P}{2}\right) \\ &= \tan\frac{P}{2} \\ &= \text{R.H.S.}\end{aligned}$$

Solution 12.

$$\cos \theta = \sin 60^\circ$$

$$\Rightarrow \cos \theta = \frac{\sqrt{3}}{2}$$

$$\Rightarrow \cos \theta = \cos 30^\circ$$

$$\Rightarrow \theta = 30^\circ$$

Now,

$$1 - 2 \sin^2 \theta = 1 - 2 \sin^2 30^\circ = 1 - 2 \times \left(\frac{1}{2}\right)^2 = 1 - 2 \times \frac{1}{4} = 1 - \frac{1}{2} = \frac{1}{2}$$

Solution 13.

$$\sec \theta = \operatorname{cosec} 30^\circ$$

$$\Rightarrow \sec \theta = 2$$

$$\Rightarrow \sec \theta = \sec 60^\circ$$

$$\Rightarrow \theta = 60^\circ$$

Now,

$$4 \sin^2 \theta - 2 \cos^2 \theta$$
$$= 4 \sin^2 60^\circ - 2 \cos^2 60^\circ$$

$$= 4 \times \left(\frac{\sqrt{3}}{2}\right)^2 - 2 \times \left(\frac{1}{2}\right)^2$$

$$= 4 \times \frac{3}{4} - 2 \times \frac{1}{4}$$

$$= 3 - \frac{1}{2}$$

$$= \frac{6-1}{2}$$

$$= \frac{5}{2}$$

Solution 14a.

$$\begin{aligned} \text{L.H.S.} &= \tan \theta \tan (90^\circ - \theta) \\ &= \cot (90^\circ - \theta) \times \cot \theta \\ &= \cot \theta \cot (90^\circ - \theta) \\ &= \text{R.H.S.} \end{aligned}$$

Solution 14b.

$$\begin{aligned}\text{L.H.S.} &= \sin 58^\circ \sec 32^\circ + \cos 58^\circ \operatorname{cosec} 32^\circ \\ &= \sin (90^\circ - 32^\circ) \times \frac{1}{\cos 32^\circ} + \cos (90^\circ - 32^\circ) \times \frac{1}{\sin 32^\circ} \\ &= \cos 32^\circ \times \frac{1}{\cos 32^\circ} + \sin 32^\circ \times \frac{1}{\sin 32^\circ} \\ &= 1 + 1 \\ &= 2 \\ &= \text{R.H.S.}\end{aligned}$$

Solution 14c.

$$\begin{aligned}\text{L.H.S.} &= \frac{\tan (90^\circ - \theta) \cot \theta}{\operatorname{cosec}^2 \theta} \\ &= \frac{\cot \theta \times \cot \theta}{\operatorname{cosec}^2 \theta} \\ &= \frac{\cot^2 \theta}{\operatorname{cosec}^2 \theta} \\ &= \frac{\cos^2 \theta}{\sin^2 \theta} \\ &= \frac{1}{\sin^2 \theta} \\ &= \cos^2 \theta \\ &= \text{R.H.S.}\end{aligned}$$

Solution 14d.

$$\begin{aligned}\text{L.H.S.} &= \sin^2 30^\circ + \cos^2 30^\circ \\ &= \left(\frac{1}{2}\right)^2 + \left(\frac{\sqrt{3}}{2}\right)^2 \\ &= \frac{1}{4} + \frac{3}{4} \\ &= \frac{4}{4} \\ &= 1 \\ &= \frac{1}{2} \times \sec 60^\circ \\ &= \text{R.H.S.}\end{aligned}$$

Solution 15.

$$A + B = 90^\circ$$

$$\Rightarrow B = 90^\circ - A$$

$$\begin{aligned} \text{L.H.S.} &= \frac{\tan A \tan B + \tan A \cot B}{\sin A \sec B} - \frac{\sin^2 B}{\cos^2 A} \\ &= \frac{\tan A \tan (90^\circ - A) + \tan A \cot (90^\circ - A)}{\sin A \sec (90^\circ - A)} - \frac{\sin^2 (90^\circ - A)}{\cos^2 A} \\ &= \frac{\tan A \cot A + \tan A \tan A}{\sin A \operatorname{cosec} A} - \frac{\cos^2 A}{\cos^2 A} \\ &= \frac{1 + \tan^2 A}{1} - 1 \\ &= 1 + \tan^2 A - 1 \\ &= \tan^2 A \\ &= \text{R.H.S.} \end{aligned}$$