

# Refraction of Light

---

## Exercise – 1

### Question 1.

- (a) What do you understand by the term refraction of light?  
(b) How does the light deviate when it travels from ?

1. a rarer to a denser medium
2. a denser to a rarer medium?

### Answer:

- (a) **Refraction of light** : “When light travels from one optical medium to other optical medium, it changes its path, this change in path is called refraction of light”.  
(b) (i) Towards the normal, (ii) Away from normal.

### Question 2.

- (a) State the laws of refraction.  
(b) What do you understand by the statement that refractive index of water is 1.33 ?

### Answer:

#### (a) Laws of refraction :

(i) **Snell’s law** : The ratio between the values of the sine of angle of incidence and the sine of angle of refraction for two given optical media is a constant quantity.

$$\mu = \sin i / \sin r$$

(ii) The incident ray, the refracted ray and the normal lie on the same plane at the point of incidence.

(b) Refractive index of water is 1.33 means that speed of light in air is 1.33 times faster than in water.

### Question 3.

Describe how will you verify the laws of refraction ?

### Answer:

#### Experiment To Verify The Laws :

Fix a white sheet of paper on a drawing board. Place a rectangular glass slab in the middle of paper and draw its boundary with a pencil. The block is removed and on the boundary line KL a point O is chosen and a normal is drawn.

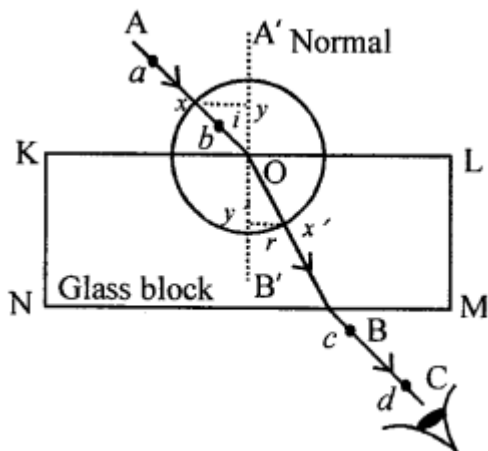

Through O a line OA at an angle  $i$  (say  $60^\circ$ ) with the normal is drawn. The block is replaced on its boundary line. Two pins a and b are fixed vertically on the board about 10 cm apart on the line AO. Looking from the other side NM of the slab two more pins c and d are fixed such that legs of pins c and d and images of pins a and b seen through glass are in a straight line.

Pins are removed and pin pricks are marked with pencil.

Slab is removed and marks c and d are joined by line BC to meet the boundary at B. OB is joined.

AO represents INCIDENT RAY

BC represents EMERGENT RAY

OB represents REFRACTED RAY

$\angle AON$  represents ANGLE OF INCIDENCE  $i$

$\angle BOM$  represents ANGLE OF REFRACTION  $r$

with O as centre and suitable radius draw a circle intersecting AO at X and OB at Y.

Draw normals XY and X' Y'. Measure XY and X' Y'.

$$\frac{XY}{X'Y'} \text{ is found to be } 1.5 = \mu$$

Or

Measure angle  $i$  and angle  $r$  then  $\frac{\sin i}{\sin r} = 1.5 = \mu$  calculated

Repeat the experiment by taking  $\angle i = 30^\circ, 40^\circ, 50^\circ$  or  $70^\circ$

$$\text{Each time } \frac{\sin i}{\sin r} = 1.5 \mu$$

Or

$$\frac{XY}{X'Y'} = 1.5\mu$$

This verifies the second law of refraction. Also Incident ray AO, refracted ray OB and normal at O are on the same paper *i.e.* on the same plane this verifies the first law of refraction.

#### Question 4.

- (a) What do you understand by the term lateral displacement ?
- (b) State three factors which determine lateral displacement ?

#### Answer:

(a) **Lateral Displacement** : "The perpendicular shift in the path of the incident ray while emerging out of an optical slab is called Lateral Displacement."

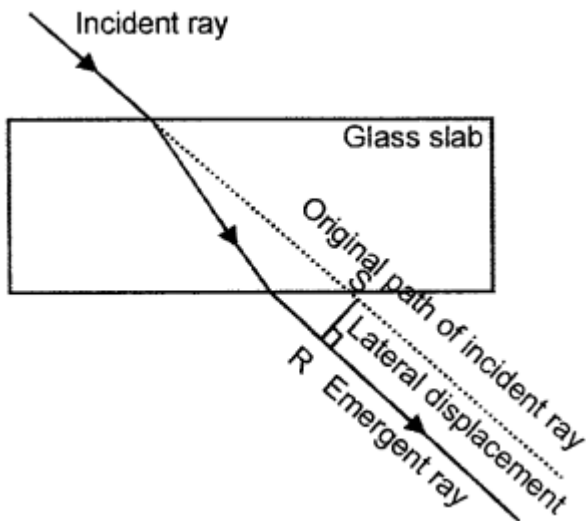

(b) Factors :

1. Angle of incidence
2. Thickness of optical slab
3. Refractive index of optical material.
4. Wavelength of light.

### Question 5.

By drawing neat diagrams explain :

- (a) Why does a stick immersed obliquely in water, appear bent and short ?
- (b) Why does a stamp placed under a glass block, appear raised?
- (c) Why is twilight formed, before sunrise or sunset ?
- (d) Why do stars twinkle, but not the planets ?
- (e) Why do the faces of people sitting around a camp fire appear to shimmer ?
- (f) Why does a tank filled with water and seen from above appear shallow ?
- (g) Why does a fisherman aim his spear at the tail of a fish during spear fishing.
- (h) Why is more than one image formed in a thick glass mirror?
- (i) Why does the sun appear bigger during sunrise or sunset?

### Answer:

(a) The stick appears to be bent and raised up in place of BA as BA' due to refraction of light on passing from denser medium (water) to rarer medium (air)

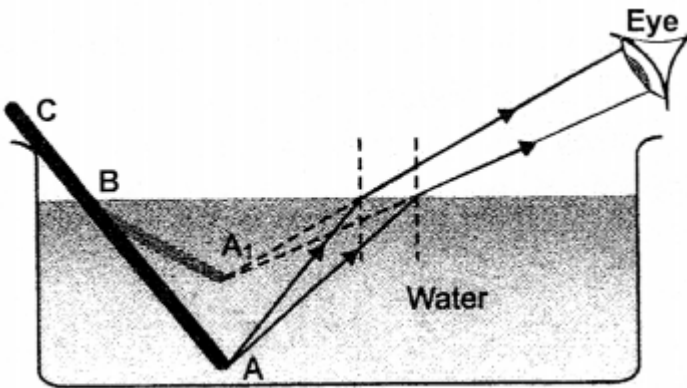

**(b)** A stamp placed under a glass block appears raised because of refraction of light as light travels from denser to rarer medium, also due to R.I of glass observed depth is less than real depth.

**(c)** Twilight is formed, before the sunrise or sun set due to refraction of sun light as even when the sun is below the horizon its rays manage to reach the earth due to refraction.

**(d)** Stars twinkle : because of refraction of light as light passes through different layers of air of different densities mix, changes the apparent position of star. When the star is with in the line of sight it is visible but when it falls out of the line of sight, it is no longer visible. The collective effect of the above changes shift the apparent position of the star and it appears to twinkle.

Planets do not twinkle : Planets are very close to us compared to the stars. Their apparent of position also changes with change of density of different layers of the atmosphere. However the size of their apparent image is still fairly large and seldom fall out side the line of sight. Hence they do not appear to twinkle.

**(e)** The rays of light reflected from the face of the person, sitting opposite to you, on passing through hot air (produced by burning wood), get refracted. Since the hot air is rapidly moving and its density is continuously changing, therefore the path of the refracted rays also changes. This gives rise to the shimmering effect and person appears to shimmer.

**(f)** Due to refraction of light when light travels from optically denser medium (water) to optically rarer medium (air) observed depth is less than real depth, and the water tank appears to be shallow.

**(g)** Due to refraction of light when light travels from denser medium (water) to rarer medium (air). The real depth is more than apparent depth.

**(h)** In a thick glass mirror, light partially gets reflected (4%) and remaining 96% passes into the glass plate suffers refraction again and again and multiple images are formed.

**(i)** Sun appears to be bigger during sun set or sun rise as "The rays of light travel through maximum length of atmosphere" due to refraction, the image of sun is very much closer to the eye. Thus, it appears bigger.

### Question 6.

What is refractive index of a material ? How is it related to (a) real and apparent depth

(b) velocity of light in vacuum or air and the velocity of light in a given medium?

**Answer:**

**Refractive index of a material :** "Is the ratio of speed of light in vacuum (air) to the speed of light in that material".

(i) Relation of R.I. :

$$\text{Refractive index} = \frac{\text{Real depth}}{\text{apparent depth}}$$

$$(ii) \text{ R.I.} = \frac{\text{vel. of light in vacuum or air}}{\text{vel. of light in medium}}$$

### Multiple Choice Questions

Tick (✓) the most appropriate option.

**1. When a beam of light strikes a glass slab a part of it is :**

- (a) reflected
- (b) absorbed
- (c) transmitted
- (d) all of these

**Answer:**

- (a) reflected

**2. The phenomenon due to which a ray of light deviates from its path while travelling from one optical medium to another optical medium is called :**

- (a) dispersion
- (b) refraction
- (c) reflection
- (d) diffraction

**Answer:**

- (b) refraction

**3. When a ray of light travelling in an optically denser medium, emerges into an optically less denser medium it :**

- (a) deviates towards the normal
- (b) deviates away from normal
- (c) does not deviate
- (d) gets reflected

**Answer:**

- (b) deviates away from normal

**4. A ray of light strikes a glass slab at  $90^\circ$ . The angle of incidence is :**

- (a)  $90^\circ$
- (b) zero
- (c) less than  $90^\circ$ , but not zero
- (d) none of these

**Answer:**

- (b) zero

**5. Two medium 'a' and 'b' have same refractive index. A ray of light travelling from medium 'a' to medium 'b'. will suffer?**

- (a) refraction at the interfaces
- (b) partly suffer reflection at the interfaces
- (c) partly gets absorbed in medium 'b'
- (d) both (b) and (c)

**Answer:**

- (b) partly suffer reflection at the interfaces

**6. A ray of light on entering from medium 'a' to medium 'b' does not suffer refraction. The angle of incidence in medium 'a' is :**

- (a)  $90^\circ$
- (b) zero
- (c)  $45^\circ$
- (d)  $60^\circ$

**Answer:**

- (b) zero

**7. During sun rise or sun set, the sun appears bigger because the rays of light coming from it pass through**

- (a) larger length of atmosphere
- (b) smaller length of atmosphere
- (c) the earth gets closer to sun
- (d) none of these

**Answer:**

- (a) larger length of atmosphere

**8. The highest refractive index is of:**

- (a) glass
- (b) water
- (c) diamond
- (d) cold air

**Answer:**

- (d) cold air

**9. During spear fishing a fisherman aims at the :**

- (a) tail of fish
- (b) head of fish
- (c) slightly ahead of the head of fish
- (d) none of these

**Answer:**

- (a) tail of fish

**10. When a ray of light enters into another optical medium, its wavelength and velocity change. The material in which wavelength and velocity decrease maximum, when the ray is travelling through air is :**

- (a) alcohol
- (b) diamond
- (c) glass
- (d) water

**Answer:**

- (b) diamond

**11. A thick glass slab with a silvered side forms multiple images on account of :**

- (a) reflection of light
- (b) dispersion of light
- (c) refraction of light
- (d) both reflection and refraction of light

**Answer:**

- (d) both reflection and refraction of light

### Numerical Problems on Refraction of Light Through Optical Slabs

#### Practice Problem 1

##### Question 1.

The velocity of light in air is  $3 \times 10^8 \text{ ms}^{-1}$  and in glass is  $2 \times 10^8 \text{ ms}^{-1}$  Find the refractive index of glass.

**Answer:**

$$\text{R.I of glass } {}_a\mu_g = \frac{\text{velocity of light in air}}{\text{velocity of light in glass}}$$

$${}_a\mu_g = \frac{3 \times 10^8}{2 \times 10^8} = 1.5$$

**Question 2.**

The velocity of light in air is  $3 \times 10^8 \text{ ms}^{-1}$ . Calculate the velocity of light in diamond or refractive index 2.5.

**Answer:**

$$\text{Vel. of light in air} = 3 \times 10^8 \text{ ms}^{-1}$$

$$\text{Vel. of light in diamond} = ?$$

$$\text{R.I. of diamond} = 2.5$$

$${}_a\mu_d = \frac{\text{velocity of light in air}}{\text{velocity of light in diamond}}$$

$$2.5 = \frac{3 \times 10^8}{\text{vel. of light in diamond}}$$

$$\therefore \text{vel. of light in diamond} = \frac{3}{2.5} \times 10^8$$

$$v_d = \frac{30}{25} \times 10^8 = 1.2 \times 10^8 \text{ ms}^{-1}$$

**Practice Problem 2****Question 1.**

The angle of refraction in a glass block of refractive index 1.5 is  $19^\circ$ . Calculate the angle of incidence.

**Answer:**

$$\text{Refractive index of glass} = \frac{\sin i}{\sin r}$$

$$1.5 = \frac{\sin i}{\sin 19^\circ}$$

$$\sin i = 1.5 \sin 19$$

**Question 2.**

Calculate the refractive index of a material, when angle of incidence in air is  $50^\circ$  and angle of refraction in the material is  $36^\circ$ .

**Answer:**

$$\text{R.I. Refractive index} = \frac{\sin i}{\sin r}$$

$$\text{R.I.} = \frac{\sin 50}{\sin 36}$$

### Practice Problem 3

#### Question 1.

A coin is placed at a depth of 15 cm in a beaker containing water. The refractive index of water is  $4/3$ , calculate height through which the image of the coin is raised.

**Answer:**

$$\text{Refractive index of water} = \frac{\text{Real depth}}{\text{Apparent depth}}$$

$$\frac{4}{3} = \frac{15\text{cm}}{x\text{cm}}$$

$$\text{Apparent depth} = x = \frac{15 \times 3}{4} = 11.25 \text{ cm}$$

$$\therefore \text{Height through which image is raised} = 15 - 11.25 = 3.75 \text{ cm}$$

#### Question 2.

The floor of a water tank appears at a depth of 2.5 m. If the refractive index of water is 1.33, find the actual depth of water.

**Answer:**

Observed depth = 2.5 m

R.I. of water = 1.33

Actual depth = ?

$$\text{R.I.} = \frac{\text{Real depth}}{\text{Apparent depth}}$$

$$1.33 = \frac{x}{2.5}$$

$$\text{Actual depth } x = 1.33 \times 2.5 = 3.325 = 3.325 \text{ m}$$

## Practice Problem 4

### Question 1.

A stone placed at the bottom of a water tank appears raised by 80 cm. If the refractive index of water is  $\frac{4}{3}$ , find the actual depth of water in the tank :

**Answer:**

Let the stone is at actual depth of =  $x$  cm

$\therefore$  observed depth =  $(x - 80)$  cm

$$\text{R.I.} = \frac{\text{Actual depth}}{\text{observed depth}}$$

$$\frac{4}{3} = \frac{x}{x - 80}$$

$$\therefore 4(x - 80) = 3x$$

$$4x - 3x = 320$$

$$\text{Actual depth} = x = 320 \text{ cm}$$

## Exercise – 2

### Question 1.

(a) What do you understand by the following terms.

1. Total internal reflection
2. Critical angle ?

(b) State two conditions for total internal reflection ?

**Answer:**

(a) (i) **Total internal reflection** : When ray of light travels from optically denser medium to optically rarer medium and  $\angle i$  is greater than critical angle  $\angle r$  becomes more than  $90^\circ$  and reflects in the same denser medium and obeys the laws of reflection. The phenomenon is called total internal reflection. Hence total internal reflection : "The phenomenon due to which, a ray of light while travelling from denser medium to rarer medium gets reflected totally internally (i.e. in the same denser medium) at the surface of separation is called total internal reflection." i.e.  $\angle A'ON = \angle B'ON$

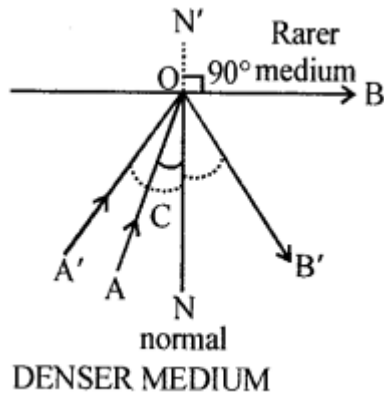

(ii) **Critical angle** : When a ray of light travels from denser to rarer medium angle of incidence for when angle of refraction is of  $90^\circ$ , then this angle of incidence is called critical angle" i.e.  $\angle AON = \text{critical angle}$

$\therefore$  Angle of refraction  $\angle N'OB = 90^\circ$

(b) **Two conditions for total internal reflection :**

1. light should travel from denser to rarer medium.
2. Angle of incidence should be more than critical angle.

### Question 2.

(a) What do you understand by the statement, "critical angle for water is  $48^\circ$  ?

(b) Explain, how that refractive index of material is related to the critical angle.

### Answer:

(a) The statement the critical angle for water is  $48^\circ$  means if light in water travels at  $\angle i = 48^\circ$  it will come out in air along the surface of water [i.e.  $\angle r = 90^\circ$  ]

(b) R.I. is related to critical angle as

$$\text{R.I.} = \frac{1}{\sin I_c} = \frac{1}{\sin \text{of critical angle}}$$

$$\text{R.I.} = \frac{1}{\sin C}$$

### Question 3.

Explain the following :

(a) An empty test tube placed obliquely in water, appears to be filled with mercury.

(b) Bubbles rising up in a fish tank appear silvery.

- (c) Air bubbles trapped in a glass paper weight appear silvery.
- (d) A crack in window pane appear silvery.
- (e) Diamonds sparkle for sometime in dark.
- (f) The top surface of water contained in a beaker and held above the eye level appear silvery.

**Answer:**

(a) An empty test tube placed in water with its mouth up ward and out side the water surface shines like mercury when seen at certain angle greater than critical angle of water. This is due to total internal reflection of light.

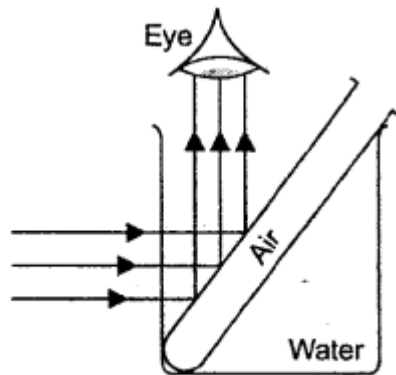

- (b) This is due to total internal reflection. When light rays strike the bubbles at angle greater than  $48^\circ$  which is critical angle of water.
- (c) This is due to total internal reflection of light. Light rays strike the glass-air interface at angle more than critical angle of glass ( $42^\circ$ ) and get totally internally reflected.
- (d) A crack in a glass window pane appear silvery on account of the presence of air in the crack due to total internal reflection.
- (e) Diamond is cut in such a way that a number of refracting surfaces are present and total internal reflection takes place at a number of places and critical angle of diamond beings  $24^\circ$  cuts at very sharp angles are made so that the ray gets trapped with in the diamond for some time.
- (f) When light gets totally internally reflected at water air interface, it appears silvery.

**Question 4.**

- (a) What is a totally reflecting prism ?
- (b) By drawing neat diagram explain how totally reflecting prisms are used to turn (i) rays through  $90^\circ$  (ii) rays through  $180^\circ$ .
- (c) How is a totally reflecting prism used as an erecting prism ?

**Answer:**

(a) **Totally reflecting prism** : "A prism having on angle of  $90^\circ$  between its two refraction surfaces and the other two angles each equal to  $45^\circ$  is called total reflecting prism

because the light incident normally on any of its faces, suffers total internal reflection inside the prisms."

(b)

1. To turn rays through  $90^\circ$

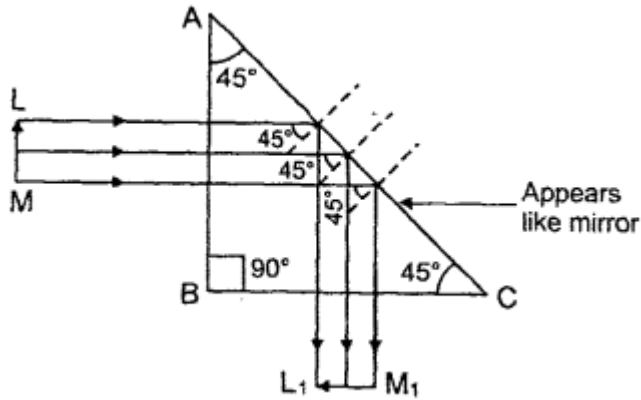

2. To turn rays through  $180^\circ$

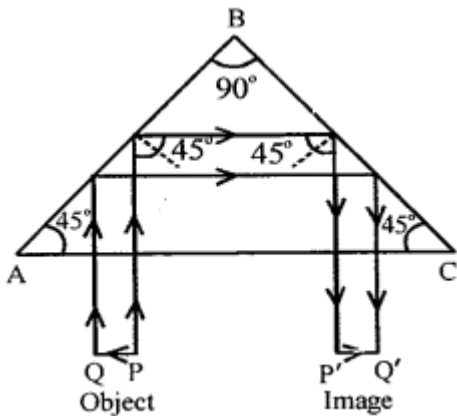

(c) Totally reflecting prism as erecting prism :

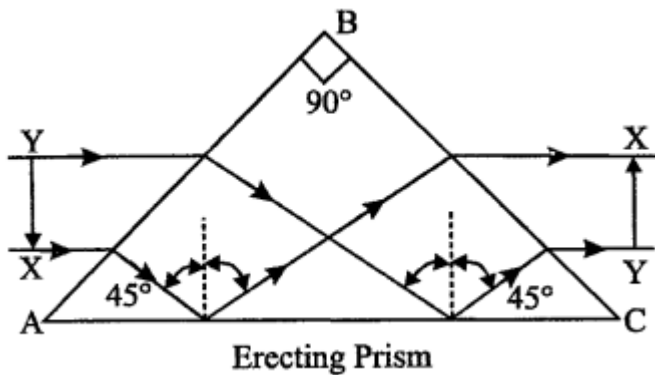

Light rays from object PQ suffer refraction air to glass and strike the face AC of prism from glass to air at angle greater than critical angle ( $42^\circ$ ) and suffers total internal reflection. Then strikes face BC at angle less than critical angle and suffers refraction

from glass to air and bends away from normal and beam emerges parallel to face AC. Erect image P'Q' is obtained and prism acts as erecting prism.

**Question 5.**

(a) Trace the course of rays through an equilateral glass prism, showing clearly

1. angle of incidence
2. angle of refraction
3. angle of the prism
4. angle of deviation
5. angle of emergence.

(b) On what factors do the angle of deviation in a prism depend?

(c) What do you understand by the term angle of minimum deviation ? In this position how is the angle of incidence related to the angle of emergence ?

**Answer:**

(a) **The course of rays through equilateral glass prism :**

1.  $\angle OPN$  – angle of incidence
2. Angle of refraction  $\angle NPQ$  is angle of refraction



3.  $\angle BAC$  is angle of prism.
4. Angle of deviation  $\angle LMR$
5. Angle of emergence  $e$

(b) **Factors effecting the angle of deviation :**

1. The angle of incidence  $i$
2. Angle of prism ( $A$ )
3. Colour of wavelength ( $\lambda$ ) of light used.
4. R.I. of prism (material of prism).

(c) **Angle of minimum deviation :** The angle between incident ray produced and emergent ray produced is called angle of deviation. The angle of deviation decreases

with increase in angle of incidence. A stage comes when for a particular value of angle of incidence, the angle of deviation is minimum.

If the angle of incidence is further increased, the angle, of deviation starts increasing.

Hence

Angle of minimum deviation is the angle of incidence for which angle of deviation is minimum.

### Question 6.

State four differences between reflection and total internal reflection.

**Answer:**

**Total Internal Reflection :**

1. The entire light is reflected.
2. There is no loss of energy.
3. It takes place only when light passes from denser to rarer medium at an angle of incidence is greater than critical angle.
4. The image is much brighter.

**Reflection :**

1. Only a part of light is reflected Rest is refracted and absorbed.
2. The energy of reflected ray is less than incident ray.
3. It takes place when light is incident on plane mirror from any medium at any angle of incidence.
4. The image is less bright.

### Multiple Choice Questions

**Tick (✓) the most appropriate option.**

**1. For total internal reflection to take place a ray of light must :**

- (a) travel from denser to rarer medium
- (b) travel from rarer to denser medium
- (c) medium does not play any role
- (d) none of these

**Answer:**

- (a) travel from denser to rarer medium

**2. The critical angle for glass is  $42^\circ$ . The corresponding angle of refraction is :**

- (a)  $0^\circ$
- (b)  $90^\circ$
- (c) lesser than  $90^\circ$  but more than  $42^\circ$

(d) no angle of refraction.

**Answer:**

(b)  $90^\circ$

**3. The critical angle for a material X is  $45^\circ$ . The total internal reflection will take place, if the angle of incidence in the denser medium is :**

(a) less than  $45^\circ$

(b)  $90^\circ$

(c) more than  $45^\circ$ , but not  $90^\circ$

(d) less than  $45^\circ$ , but not zero degree

**Answer:**

(c) more than  $45^\circ$ , but not  $90^\circ$

**4. Diamonds sparkle more than the glass, because they have :**

(a) smaller critical angle than the glass

(b) larger critical angle than the glass

(c) critical angle plays no role

(d) none of these

**Answer:**

(c) critical angle plays no role

**5. Small air bubbles rising up a fish tank appear silvery when viewed from some particular angle because of the phenomenon of :**

(a) reflection

(b) refraction

(c) total internal reflection

(d) dispersion

**Answer:**

(c) total internal reflection

**6. An isosceles totally reflecting prism can reflect rays through an angle of :**

(a)  $60^\circ$

(b)  $90^\circ$

(c)  $180^\circ$

(d) both (b) and (c)

**Answer:**

(d) both (b) and (c)

**7. A ray of light is incident on the face of an equilateral prism at angle of  $90^\circ$ . The ray gets totally reflected on the second refracting face. The total deviation produced in the path of ray is :**

(a)  $60^\circ$

(b)  $90^\circ$

- (c)  $120^\circ$
- (d)  $180^\circ$

**Answer:**

- (c)  $120^\circ$

**8. A crack in the window pane appears silvery when viewed from some particular angle. This phenomenon due to :**

- (a) reflection of light
- (b) refraction of light
- (c) total internal reflection of light
- (d) dispersion of light

**Answer:**

- (c) total internal reflection of light

**9. When an equilateral prism is in minimum deviation position the angle of incidence is :**

- (a) greater than the angle of emergence
- (b) smaller than the angle of emergence
- (c) equal to the angle of emergence
- (d) none of these

**Answer:**

- (c) equal to the angle of emergence

**10. A prism has :**

- (a) two rectangular and three triangular surfaces
- (b) two triangular and three rectangular surfaces
- (c) three rectangular and three triangular surfaces
- (d) none of these

**Answer:**

- (b) two triangular and three rectangular surfaces

**11. When a ray of light passes through an equilateral glass prism :**

- (a) it suffers refraction on the first refracting surfaces
- (b) it suffers refraction on both the refracting surfaces
- (c) it bends towards the base on both refracting surfaces
- (d) both (b) and (c)

**Answer:**

- (d) both (b) and (c)

## Numerical Problems on Lenses

### Practice Problems 1

### Question 1.

A convex lens of focal length 10 cm is placed at a distance of 60 cm from a screen. How far from the lens should be placed an object so as to obtain a real image on the screen? Calculate the magnification of the image and its characteristics.

**Answer:**

Here  $v = 60$  cm

$f = 10$  cm

$$\Rightarrow \frac{1}{v} - \frac{1}{u} = \frac{1}{f} \quad \Rightarrow \frac{1}{60} - \frac{1}{u} = \frac{1}{10}$$

$$\Rightarrow -\frac{1}{u} = \frac{1}{10} - \frac{1}{60} = \frac{6-1}{60} = \frac{5}{60} = \frac{1}{12}$$

$$\Rightarrow \frac{1}{u} = -\frac{1}{12}$$

$\therefore u = -12$  cm  $\quad \because u$  is taken -ve.

Magnification :

$$\Rightarrow m = \frac{v}{u} = \frac{60}{-12} = -5$$

$\therefore$  Image is real, inverted and enlarged *i.e.* 5 times that of object

### Question 2.

An object of height 3 cm is placed at a distance of 24 cm from a convex lens of focal length 10 cm, when an image is formed on the screen on the other side of the lens. Calculate

- (a) the distance of the screen from the lens
- (b) the size of image
- (c) the characteristics of image.

**Answer:**

$$h_1 = 3 \text{ cm}$$

$$u = 24 \text{ cm}$$

$$f = 10 \text{ cm}$$

$$\Rightarrow \frac{1}{v} = \frac{1}{u} = \frac{1}{f} \quad \Rightarrow \frac{1}{v} = \frac{1}{f} + \frac{1}{u}$$

$$\Rightarrow \frac{1}{v} = \frac{1}{10} - \frac{1}{24} = \frac{12-5}{120} = \frac{7}{120}$$

$$(a) \quad v = \frac{120}{7} = 17.14 \text{ cm}$$

(b) Size of image  $h_2$

$$m = \frac{v}{u} = \frac{h_2}{h_1}$$

$$\Rightarrow \frac{120}{7} \times 24 = \frac{h_2}{3}$$

$$h_2 = \frac{5}{7} \times 3 = \frac{15}{7} = 2.14 \text{ cm}$$

(c) Characteristics of image

(i) Real      (ii) Inverted      (iii) Diminished

## Practice Problems 2

### Question 1.

An object when placed in front of a convex lens forms a real image of 0.5 magnification. If the distance of the image from the lens is 24 cm, calculate focal length of the lens.

**Answer:**

$$u = ? \quad m = 0.5$$

$$v = 24 \text{ cm}$$

$$f = ?$$

$$\Rightarrow m = \frac{v}{u} = \frac{24}{u}$$

$$\Rightarrow 0.5 = \frac{1}{2} = \frac{24}{u} \quad \therefore u = 48 \text{ cm}$$

$$\Rightarrow \frac{1}{f} = \frac{1}{v} - \frac{1}{u}$$

$$\Rightarrow f = \frac{1}{24} = \frac{1}{48} = \frac{2-1}{48} = \frac{1}{48}$$

$$f = 48 \text{ cm}$$

If in the question 24 cm is distance of object from lens, then

$$m = \frac{v}{u} \quad \Rightarrow \frac{1}{2} = \frac{v}{24} \quad \therefore v = \frac{24}{2} = 12 \text{ cm}$$

$$\Rightarrow \frac{1}{f} = \frac{1}{v} - \frac{1}{u}$$

$$\Rightarrow \frac{1}{f} = \frac{1}{12} - \left( \frac{1}{-24} \right)$$

$$\Rightarrow \frac{1}{f} = \frac{1}{12} + \frac{1}{24} = \frac{2+1}{24} = \frac{3}{24}$$

$$\Rightarrow f = \frac{24}{3} = 8 \text{ cm}$$

### Question 2.

A convex lens forms a real image 4 times magnified when placed at a distance of 6 cm from the lens. Calculate the focal length of the lens.

**Answer:**

$$m = 4$$

$$u = 6 \text{ cm}$$

$$v = ?$$

$$m = \frac{v}{u}$$

$$\Rightarrow u = \frac{v}{4} \qquad \therefore v = 4 \times 6 = 24 \text{ cm}$$

$$\frac{1}{f} = \frac{1}{v} - \frac{1}{u}$$

$$\Rightarrow \frac{1}{f} = \frac{1}{24} - \left( \frac{1}{-6} \right) = \frac{1}{24} + \frac{1}{6} = \frac{1+4}{24}$$

$$\Rightarrow \frac{1}{f} = \frac{5}{24} \qquad \therefore f = \frac{24}{5} = 4.8 \text{ cm}$$

### Practice Problems 3

#### Question 1.

An object 1.4 cm high when placed in front of a convex lens at a distance of 6 cm, forms a virtual image at a distance of 24 cm from the lens. Calculate

- (a) the focal length of the lens
- (b) the size of the image.

**Answer:**

$$h_1 = 1.4 \text{ cm}$$

$$u = -6 \text{ cm}$$

$$v = -24$$

( $\because$  Image formed is virtual)

$$(a) \frac{1}{f} = \frac{1}{v} - \frac{1}{u}$$

$$\Rightarrow \frac{1}{f} = -\frac{1}{24} - \left(-\frac{1}{6}\right)$$

$$\Rightarrow \frac{1}{f} = -\frac{1}{24} + \frac{1}{6} = \frac{-1+4}{24} = \frac{3}{24} = \frac{1}{8}$$

$$\Rightarrow f = 8 \text{ cm}$$

$$(b) m = \frac{h_2}{h_1} = \frac{v}{u}$$

$$\Rightarrow \frac{h_2}{1.4} = \frac{-24}{-6} = 4$$

$$h_2 = 4 \times 1.4 = 5.6 \text{ cm}$$

**Question 2.**

A convex lens forms a 2.5 times magnified virtual image when an object is placed at a distance of 8 cm from the lens. Calculate

(a) the distance of the image from the lens

(b) the focal length of lens.

**Answer:**

$$m = 2.5$$

$$u = -8 \text{ cm}$$

$$(a) \quad m = \frac{v}{u}$$

$$\Rightarrow 2.5 = \frac{v}{-8}$$

$$\Rightarrow v = -20 \text{ cm} \qquad \therefore v = 20 \text{ cm}$$

$$(b) \quad \frac{1}{f} = \frac{1}{v} - \frac{1}{u}$$

$$\Rightarrow \frac{1}{f} = -\frac{1}{20} - \left(-\frac{1}{8}\right) = \frac{-1}{20} + \frac{1}{8}$$

$$\frac{1}{f} = \frac{-2+5}{40} = \frac{3}{40} \qquad \therefore f = \frac{40}{3} = 13.3 \text{ cm}$$

**Question 3.**

An object 1 cm high is placed at a distance of 4 cm from a convex lens of focal length 6 cm. Calculate

(a) the position of the image

(b) size of a image. State the characteristics of the image.

**Answer:**

$$h_1 = 1 \text{ cm}$$

$$u = -4 \text{ cm}$$

$$f = 6 \text{ cm}$$

$$(a) \quad \frac{1}{v} - \frac{1}{u} = \frac{1}{f}$$

$$\Rightarrow \frac{1}{v} = \frac{1}{f} + \frac{1}{u}$$

$$\Rightarrow \frac{1}{v} = \frac{1}{6} + \left(\frac{-1}{4}\right) = \frac{2-3}{12} = \frac{-1}{12}$$

$$\Rightarrow v = -12 \text{ cm}$$

(a)  $\therefore$  Distance of image from lens is 12 cm

(b) Size of Image  $h_2$

$$\Rightarrow m = \frac{v}{u} = \frac{h_2}{h_1}$$

$$\Rightarrow \frac{-12}{-4} = \frac{h_2}{1} \quad \Rightarrow h_2 = 3 \text{ cm}$$

#### Practice Problems 4

##### Question 1.

An object 2 cm high is placed at a distance of 25 cm from the optical centre of a concave lens of focal length 15 cm. Calculate

(a) the position of the image

(b) the size of the image.

**Answer:**

$$h_1 = 2 \text{ cm}$$

$$u = -25 \text{ cm}$$

$$f = -15 \text{ cm}$$

(a) Position of image  $v = ?$

$$\frac{1}{f} - \frac{1}{v} = \frac{1}{u}$$

$$\therefore \frac{1}{v} = \frac{1}{f} + \frac{1}{u}$$

$$\Rightarrow \frac{1}{v} = -\frac{1}{15} - \frac{1}{25} = \frac{-5-3}{75} = \frac{-8}{75}$$

$$\Rightarrow v = \frac{-75}{8} = -9.37 \text{ cm}$$

(b) Size of image  $h_2 = ?$

$$m = \frac{v}{u} = \frac{h_2}{h_1}$$

$$\Rightarrow \frac{-75}{8 \times -25} = \frac{h_2}{2}$$

$$\Rightarrow \frac{h_2}{2} = \frac{3}{8} \qquad \therefore h_2 = \frac{3}{8} \times 2 = \frac{3}{4} = 0.75 \text{ cm}$$

### Question 2.

A concave lens forms 4 times diminished and virtual image when an object is placed at a distance of 80 cm. Calculate

- (a) the position of the image
- (b) the focal length of the lens.

**Answer:**

$$m = \frac{1}{4} \quad u = 80 \text{ cm} \quad v = ?$$

(a)  $m = \frac{v}{u}$

$$\frac{1}{4} = \frac{v}{80} \quad \therefore v = \frac{80}{4} = 20 \text{ cm}$$

(b) Focal length of lens

$$f = ?$$

$$\frac{1}{f} = \frac{1}{v} - \frac{1}{u}$$

$$\Rightarrow \frac{1}{f} = -\frac{1}{20} - \left(-\frac{1}{80}\right)$$

$$\Rightarrow \frac{1}{f} = -\frac{1}{20} + \frac{1}{80} = \frac{-4+1}{80}$$

$$\Rightarrow \frac{1}{f} = \frac{-3}{80}$$

$$\Rightarrow f = -\frac{80}{3} = -26.67 \text{ cm}$$

**Question 3.**

A concave lens has focal length 15 cm. At what distance should the object from the lens be placed, so as to form an image at 10 cm from the lens. Also find magnification of the lens.

**Answer:**

$$f = 15 \text{ cm}$$

$$u = ? \quad v = -10 \text{ cm} \quad \therefore \text{lens is concave.}$$

$$\frac{1}{f} = \frac{1}{v} - \frac{1}{u}$$

$$\therefore \frac{1}{u} = \frac{1}{v} - \frac{1}{f}$$

$$\Rightarrow \frac{1}{u} = -\frac{1}{10} - \left(\frac{-1}{15}\right)$$

$$\Rightarrow \frac{1}{u} = -\frac{1}{10} + \frac{1}{15} = \frac{-3+2}{30} = \frac{-1}{30}$$

$$(a) \therefore u = -30 \text{ cm}$$

$$(b) m = \frac{v}{u} = \frac{-10}{-30} = \frac{1}{3} = 0.33$$

### Practice Problems 5

#### Question 1.

A converging lens has a focal length 40 cm. Calculate its power.

**Answer:**

Converging lens means convex lens has focal length +ve

$$f = 40 \text{ cm} = \frac{40}{100} \text{ m}$$

$$\therefore \text{Power of lens} = \frac{1}{f} \text{ expressed in metres}$$

$$P = \frac{100}{40} = + 2.5 \text{ D}$$

#### Question 2.

A lens which forms a real image has a focal length 8 cm. Calculate its power.

**Answer:**

$$\text{Focal length} = 8 \text{ cm} = \frac{8}{100} \text{ m}$$

$$\text{Power } P = \frac{1}{f} \text{ expressed in metres}$$

$$P = \frac{1}{\frac{8}{100}} = \frac{100}{8} = +12.5 \text{ D}$$

### Practice Problems 6

#### Question 1.

State the nature of the lens and the focal length if its power is +4D.

**Answer:**

(a) Power = +4D

(+ve sign shows that lens is convex)

(b)  $P = \frac{100}{f}$

$$\Rightarrow 4 = \frac{100}{f}$$

$$\Rightarrow f = \frac{100}{4} = 25 \text{ cm}$$

#### Question 2.

The number of the glasses of a person is +0.75 D. What is the nature of the lens and what is its focal length ?

**Answer:**

(a) Number of glasses = Power = + 0.75 D

(+ ve sign shows that lens is convex)

$$(b) P = \frac{100}{f}$$

$$\Rightarrow 0.75 = \frac{100}{f}$$

$$\Rightarrow f = \frac{100}{0.75} = \frac{100 \times 100}{75}$$

$$\Rightarrow f = 133.33 \text{ cm}$$

### Practice Problems 7

#### Question 1.

The focal length of a concave lens is 10 cm. Calculate its power.

**Answer:**

Concave lens has -ve focal length

$$f = -10 \text{ cm}$$

$$P = \frac{100}{f} = \frac{100}{-10} = -10D$$

#### Question 2.

The focal length of the lens of a myopic person is 40 cm. What is the power of the lens ?

**Answer:**

Myopic person uses concave lens

$$f = -40 \text{ cm}$$

$$P = \frac{100}{f} = \frac{100}{-40} = -2.5 D$$

### Practice Problems 8

**Question 1.**

Calculate the focal length of a lens of power -2.75 D.

**Answer:**

$$\text{Power } P = -2.75 \text{ D}$$

$$P = \frac{100}{f}$$

$$\Rightarrow -2.75 = \frac{100}{f}$$

$$\Rightarrow f = \frac{-100 \times 100}{275} = \frac{-400}{11} = -36.36 \text{ cm}$$

$$\Rightarrow f = -36.36 \text{ cm}$$

**Question 2.**

The power of a concave lens is -12.5 D. What is the focal length of the lens ?

**Answer:**

$$\text{Power of concave lens } P = -12.5 \text{ D}$$

$$\Rightarrow P = \frac{100}{f}$$

$$\Rightarrow f = \frac{100}{P}$$

$$\Rightarrow f = \frac{-100}{12.5} = \frac{-1000}{125} = \frac{-40}{5} = -8$$

$$\Rightarrow f = -8 \text{ cm}$$

**Exercise – 3****Question 1.**

(a) What do you understand by the term lens ?

(b) What are the various kinds of lenses ? Draw a neat diagram of each kind.

**Answer:**

**(a) Lens :** "Is a piece of transparent optical medium material having one or two spherical surfaces."



**Or**

"A lens is a transparent refracting medium bounded by two curved surfaces which are generally spherical."

**(b) There are two types of lenses :**

(i) Convex lens or converging lens 

(ii) Concave lens or diverging lens 

Convex lens  $\longrightarrow$  (i)  double convex or biconvex 

(ii) plano convex (iii)  concavo-convex

Concave lens  $\longrightarrow$  (i) B i o concave

(ii)  plano - concave (ii) plano-concave

(iii)  convex concave

**Question 2.**

Define the following with respect to converging lens

1. principal axis
2. optical centre
3. first principal focus
4. second principal focus
5. focal length.

**Answer:**

**(i) Principal axis :** "It is the line joining the centres of curvature of the two surfaces of the lens."

**(ii) Optical centre :** It is a point on the principal axis of the lens such that a ray of light passing through this point emerges parallel to its direction of incidence."

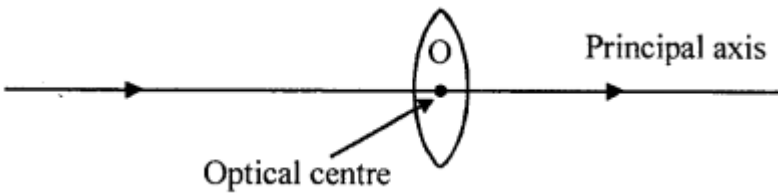

(iii) **First principal focus** : “Is a point on the principal axis of a convex lens, such that the rays starting from it, after refraction travel parallel to the principal axis.”

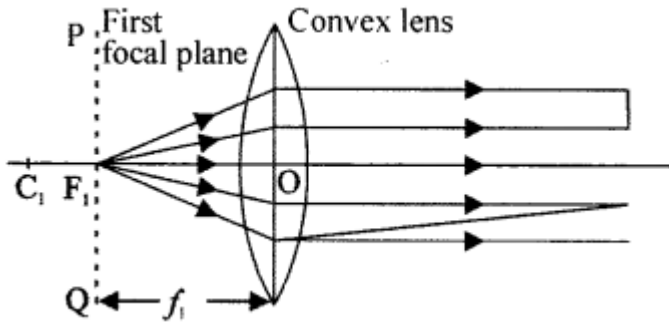

(iv) **Second Principal focus** : “It is a point on the principal axis, such that rays coming parallel to the principal axis after refraction through the lens actually meet here.”

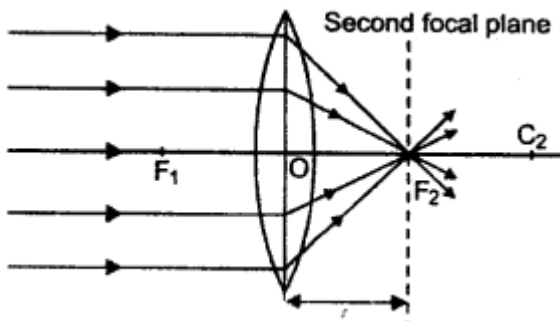

(v) **Focal Length** : “The distance between focus and optical centre of a lens is called focal lens.”

**Question 3.**

Draw neat diagrams for the formation of images in case of convex lens and state its characteristics when the object is :

1. at infinity
2. between 2F and infinity
3. at 2F
4. in between F and 2F
5. at F.

**Answer:**

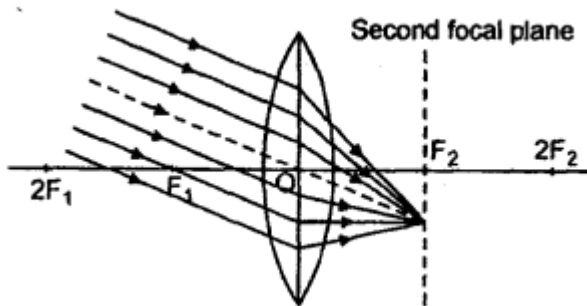

**(i) Characteristics of image :**

1. Real
2. Inverted
3. Highly diminished
4. at  $F$  on right side of lens.

**(ii) Object between  $2F$  and infinity : Image formed is**

1. Real
2. Inverted
3. Diminished
4. Between  $F$  and  $2F$ .

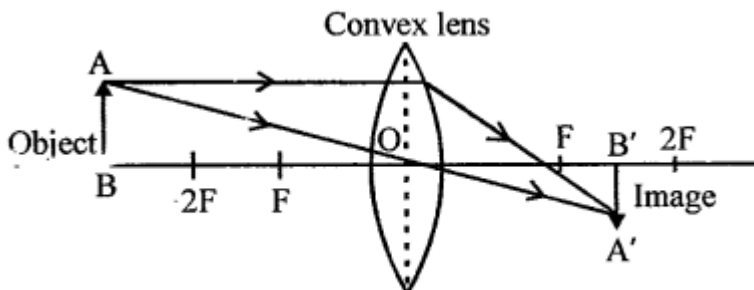

(iii) object at  $2F$

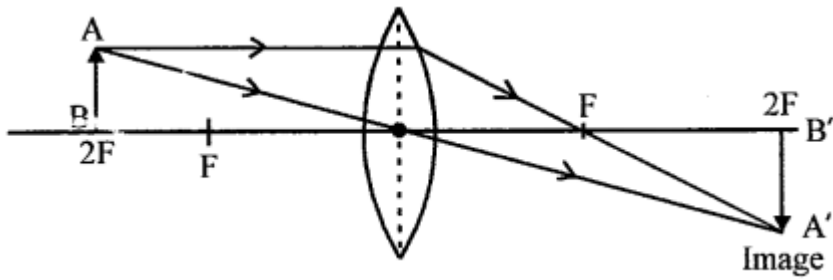

Image formed is :

1. Real
2. Inverted
3. At  $2F$  on right side of lens
4. same size of object

(iv) Object lies between  $F$  and  $2F$  :

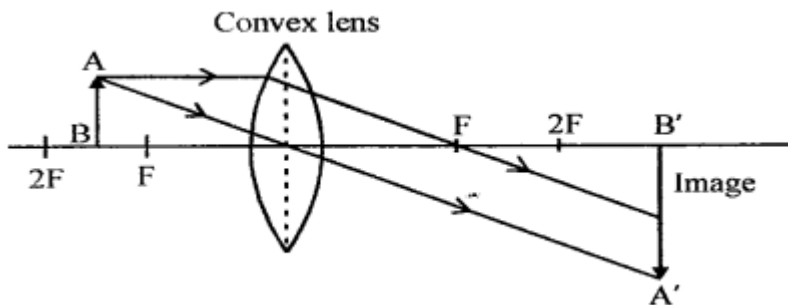
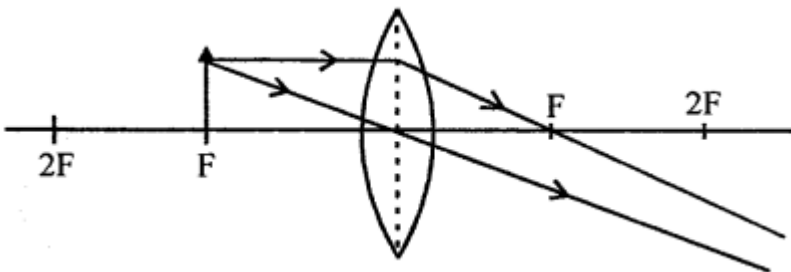

Image formed is :

1. Real
2. Inverted
3. Magnified
4. Beyond  $2F$  on Right side of lens.

(v) Object at  $F$  :



- (i) at infinity (rays after passing lens become)
- (ii) Real
- (iii) Inverted parallel

**Question 4.**

Draw a neat diagram for a simple microscope.

**Answer:**

**Diagram of simple microscope :**

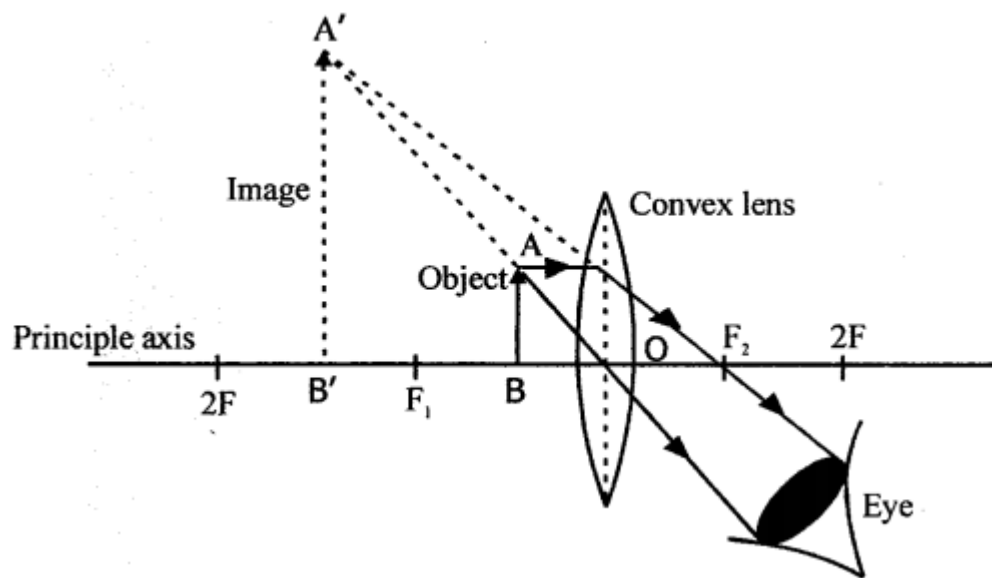

When object lies between  $F$  and lens, its image is magnified, erect and on the same side of object which can be seen by eye. Hence this arrangement acts a simple microscope.

**Question 5.**

Draw neat diagrams for the formation of images in case of concave lens and state their characteristics when the object is :

1. at infinity
2. anywhere between infinity and the optical centre

**Answer:**

**(i) Object at infinity :**

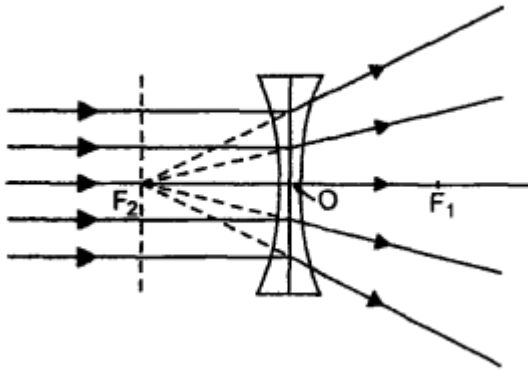

**Image formed is**

1. at second focus  $F_2$
2. virtual
3. erect
4. highly diminished.

**(ii)** Object lies anywhere between infinity and optical centre.

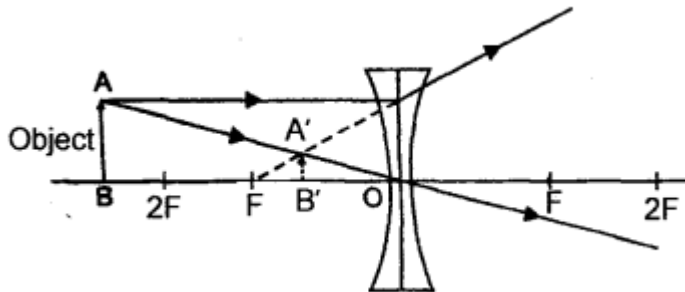

The image is formed between  $F$  and optical centre is virtual erect and diminished.

**Question 6.**

How will you find the focal length of a convex lens, by using a single pin and a plane mirror ?

**Answer:**

Since rays after refraction through lens become parallel and ray after reflection from mirror meet at original point  $S$ ,  $S$  is the focus and distance between  $S$  and lens is focal length. Even if the mirror is moved to any position, here at focal length, the parallel ray

will meet at S (i.e. focus)

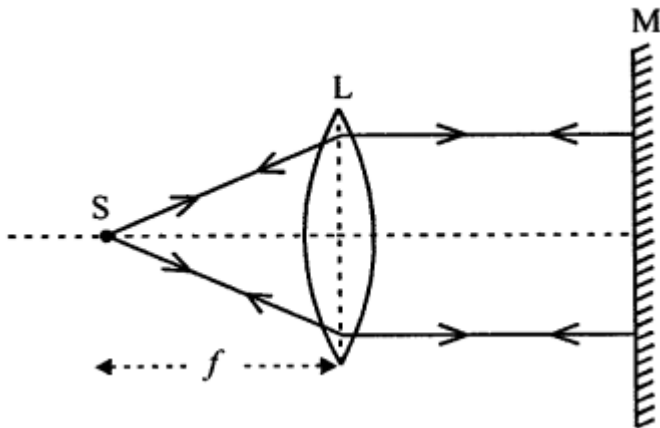

**Question 7.**

You are required to form an upright image of an object in case of (a) convex lens, (b) concave lens. What will be the position of the object with respect to the lens in each case? Support your answer by diagrams and state the characteristics of the image in each case:

**Answer:**

**Upright image of an object in case of**

**(a) Convex lens :** The position of object is between and optical centre.

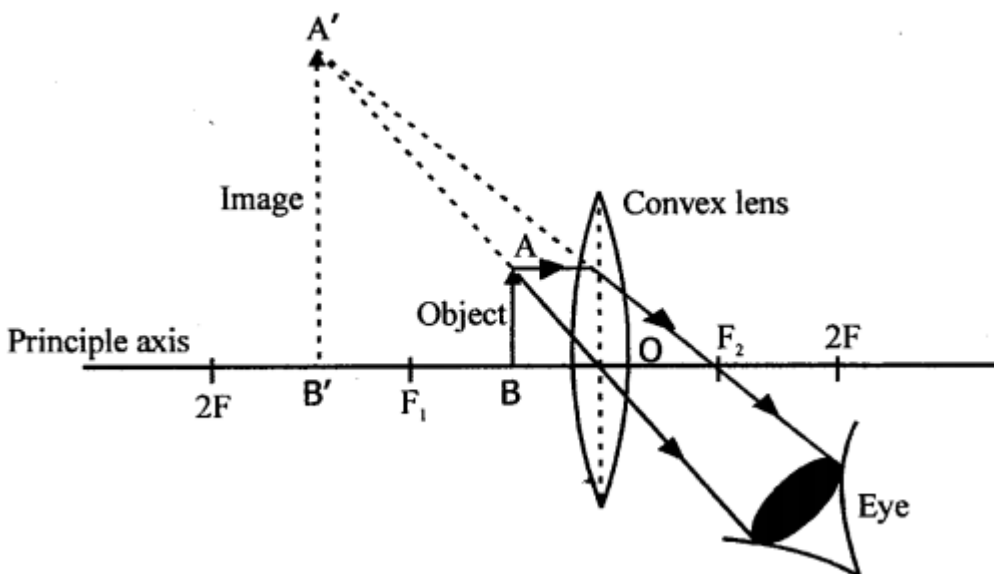

**(b) Concave lens :** The position of object is anywhere between infinity and optical

centre.

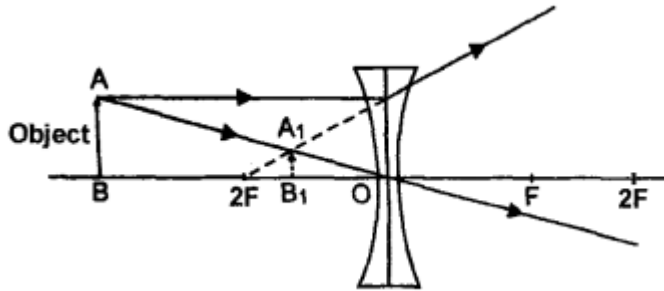

### Multiple Choice Questions

Tick (✓) the most appropriate option.

**1. The point on the principal axis of a convex lens, such that rays of light starting from it on passing through the lens, move parallel to the principal axis is called :**

- (a) first focal point
- (b) second focal point
- (c) optical centre
- (d) aperture of lens

**Answer:**

- (a) first focal point

**2. A convex lens can be regarded as a set of prisms and a glass slab, such that refracting angle of the prisms**

- (a) continuously decreases in outward direction
- (b) continuously increases in outward direction
- (c) remains same in outward direction
- (d) none of these

**Answer:**

- (a) continuously decreases in outward direction

**3. A lens forms an inverted image of an object equal to its own size. The object is :**

- (a) beyond infinity and  $2F_1$
- (b) at  $2F_1$
- (c) between  $2F_1$  and  $F_1$
- (d) in between  $F_1$  and optical centre

**Answer:**

- (b) at  $2F_1$

4. A convex lens will form a virtual, erect and enlarged image, when the object is :

- (a) between  $2F_1$  and  $F_1$
- (b)  $2F_1$
- (c)  $2F_1$  and infinity
- (d)  $F_1$  and optical centre

**Answer:**

- (d)  $F_1$  and optical centre

5. A concave lens always forms :

- (a) real, inverted and enlarged image
- (b) virtual, inverted and enlarged image
- (c) virtual, erect and diminished image
- (d) virtual, erect and enlarged image

**Answer:**

- (c) virtual, erect and diminished image

### Questions from ICSE Examination Papers

2003

#### Question 1.

(a) A ray of light, after refraction through a concave lens, emerges parallel to the principal axis. Draw a ray diagram to show the incident ray and its corresponding emergent ray.

(b) The velocity of light in diamond is  $21,000 \text{ kms}^{-1}$ . What is its refractive index of diamond? (Velocity of light in air  $3 \times 10^8 \text{ m/s}$ )

**Answer:**

(a)

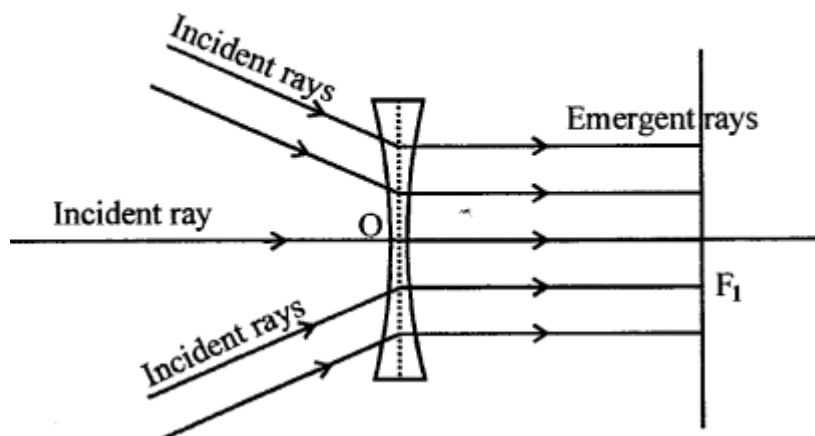

$$(b) \mu = \frac{\text{Speed of light in air}}{\text{Speed of light in medium}}$$

$$\text{Refractive Index} = \frac{3 \times 10^8}{1.21 \times 10^8} = \frac{3}{1.21} = \boxed{2.47} \text{ Ans.}$$

### Question 2.

A monochromatic point source of light 'O' is seen through a rectangular glass block ABCD. Paths of two rays, in and outside the block, are shown in figure above.

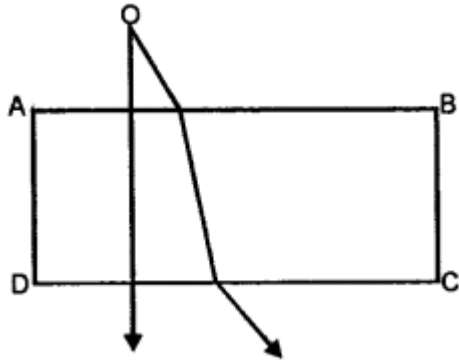

- Does the source monochromatic source appear to be nearer or farther with respect to the surface AB ?
- How does the shift in (a) depend up on the thickness (AD) of the glass block ?
- Justify your answer in (b) with an appropriate ray diagram.
- For the same rectangular block, which colour from the visible spectrum will produce the maximum shift ?

### Answer:

(a) Nearer

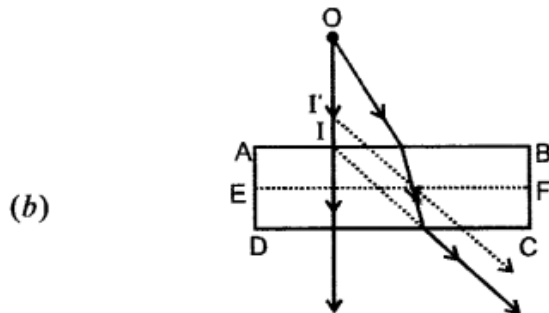

Shift is proportional to the thickness of the slab  $\therefore$  it increases with increase in thickness of slab.

- With thickness AD, the image is at I while for thickness AE ( $<$  AD), the image is at I'

and shift  $OA' < \text{shift } OI$  when thickness decreases.

(d) The same rectangular glass block will produce Maximum shift is of VIOLET COLOUR LIGHT incident on it for which the refractive index of glass is most.

**Question 3.**

A postage stamp appears raised by 7.00 mm when placed under a glass block of refractive index 1.5. Find the thickness of the glass block.

**Answer:**

$$\mu = \frac{\text{Real depth}}{\text{Apparent depth}}$$

$$1.5 = \frac{x}{x-7} \Rightarrow \frac{3}{2} = \frac{x}{x-7} \Rightarrow 3x - 21 = 2x \Rightarrow x = 21$$

Thickness of glass block = **21 mm.** Ans.

2004

**Question 4.**

(a) What do you understand by the term critical angle ?

**Answer:**

It is the angle of incidence of a light ray in a denser medium for which the angle of refraction in a rarer medium is  $90^\circ$ .

(b) Diagram below shows a path of ray AB through an isosceles right angled prism. What is the magnitude of the angle of incidence on (i) face PR (ii) PQ ?

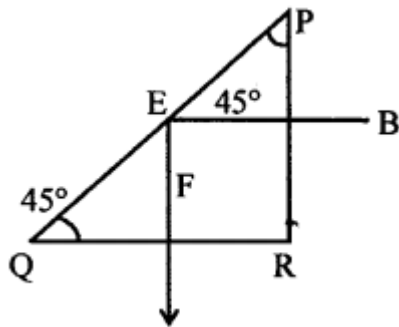

**Answer:**

Angle of incidence at the face PR is  $90^\circ$

Angle of incidence of the face PQ is  $45^\circ$

### Question 5.

The diagram given below shows the position of an object and its image. Copy the diagram and then by drawing two rays locate the position of the lens and its focus, showing clearly the kind of lens used.

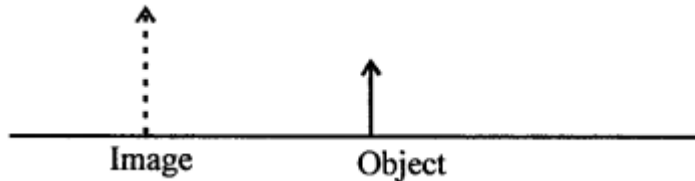

**Answer:**

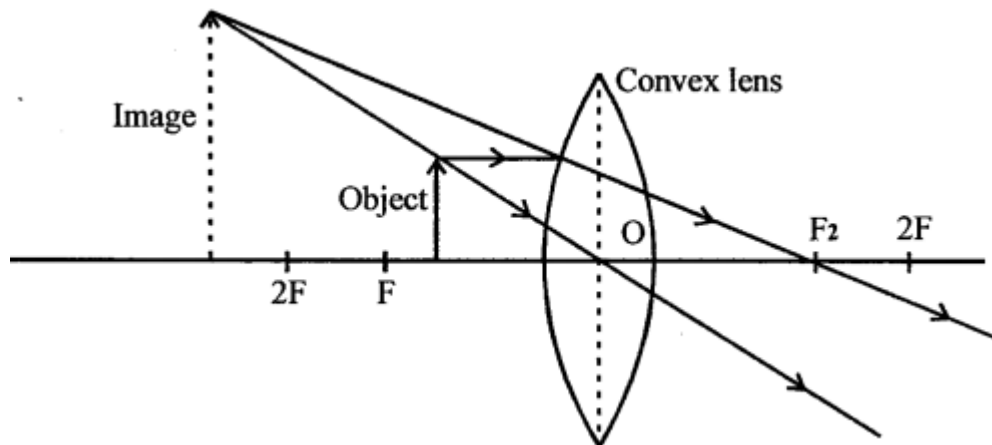

As the image is magnified and on the same side of object, the lens must be convex. The object lies within focus and lens. The lens is convex.

### Question 6.

(a) State the Snell's law of refraction.

**Answer:**

Second law of refraction i.e.  $\sin i / \sin r = \mu$  is called Snell's Law.

**SNELL'S LAW** : which states that "It is the ratio of sine of angle of INCIDENCE to sine of angle of REFRACTION is constant for a pair of media."

$$\frac{\sin i}{\sin r} = \mu = \text{constant} = RI$$

(b) If the velocity of light in air is  $3 \times 10^8 \text{ m s}^{-1}$  and refractive index of glass 1.5, calculate the velocity of light in glass.

**Answer:**

Given,  $\mu = 1.5$ ,  $V_{\text{air}} = 3 \times 10^8 \text{ m s}^{-1}$ ,  $V_{\text{glass}} = ?$

$$\text{From } \mu = \frac{V_{\text{air}}}{V_{\text{glass}}}; V_{\text{glass}} = \frac{V_{\text{air}}}{\mu} = \frac{3 \times 10^8}{1.5} \text{ m s}^{-1}$$

$$= \boxed{2 \times 10^8 \text{ ms}^{-1}}$$

2005

**Question 7.**

Mention two properties of a wave: one property which varies and the other which remains constant when the wave passes from one medium to another.

**Answer:**

1. Wavelength varies
2. Frequency remains unchanged.

**Question 8.**

What is meant by the statement 'the critical angle for diamond is  $24^\circ$ '? How is the critical angle of a material related to its refractive index?

**Answer:**

Critical angle for diamond is  $24^\circ$  means that the angle of incidence of light in diamond is such that the angle of refraction for it in air is  $90^\circ$ . The critical angle is related to the refractive index of the material as  $1/\sin i_c = \mu$ , where  $\mu =$  refractive index

**Question 9.**

The ray diagram given below illustrates the experimental set up for the determination of the focal length of a converging lens using a plane mirror.

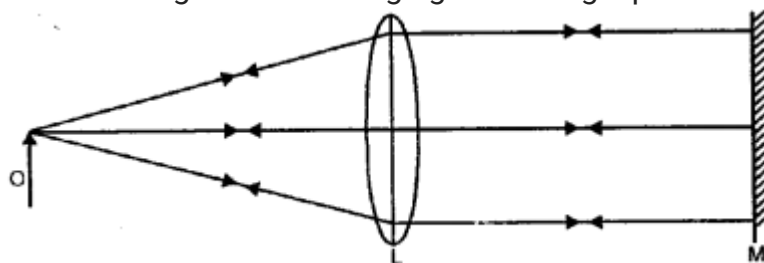

- (a) State the magnification of the image formed.
- (b) Write two characteristics of the image formed.
- (c) What name is given to the distance between the object and optical centre in the diagram above?

**Answer:**

- (a) Magnification of the image formed is of SAME SIZE as that of object.
- (b) The image formed is INVERTED and REAL.
- (c) Focal length.

2006

**Question 10.**

An object is placed in front of a convex lens such that the image formed has the same size as that of the object. Draw a ray diagram to illustrate this.

**Answer:**

When an object is placed at  $2F$ , image is formed at  $2F$  on other side of lens is of same size as of object.

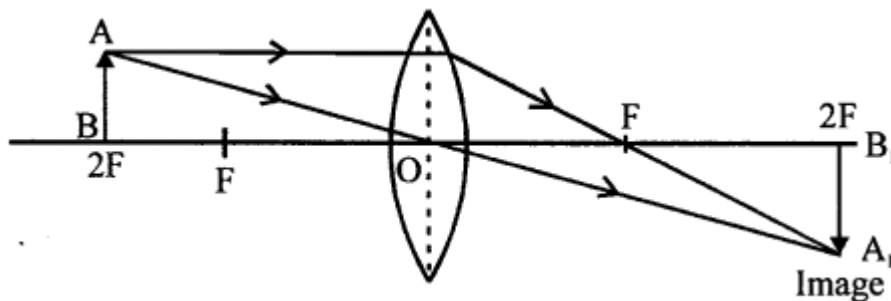

**Question 11.**

$PQ$  and  $PR$  are two light rays emerging from the object  $P$  as shown in the figure

- (a) What is the special name given to the angle of incidence ( $\angle PQN$ ) of ray  $PQ$  ?

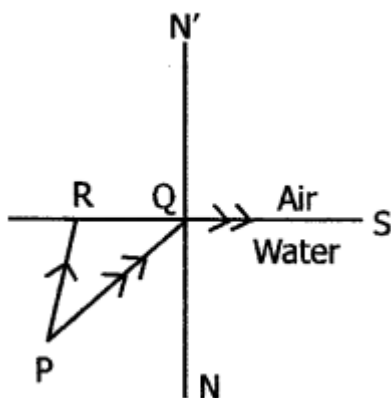

- (b) Copy the ray diagram and complete it to show the position of the image of the image of the image of the object  $P$  when seen obliquely from above.
- (c) Name the phenomenon that occurs if the angle of incidence  $\angle PQN$  is increased still further.

**Answer:**

- (a) Angle of incidence  $\angle PQN$  is Critical Angle
- (b)  $P'$  is the image of  $P$  as seen obliquely from above.
- (c) Total Internal Reflection will take place.

2007

**Question 12.**

State Snell's Law of Refraction of light.

**Answer:**

Snell's law of refraction states that for a given pair of media and for a given colour of light the ratio of the sine of the angle of incidence to the sine of angle of refraction is a constant quantity.

*i.e.,* 
$$\frac{\sin i}{\sin r} = \text{constant}$$

The constant is called refractive index of second media with respect to first media.

**Question 13.**

An object is placed in front of a converging lens at a distance greater than twice the focal length of the lens. Draw a ray diagram to show the formation of the image.

**Answer:**

The required ray diagram is as shown in the fig. below.

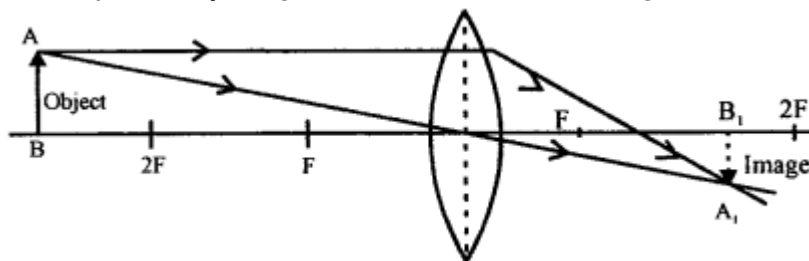

$A'B'$  is the real, inverted and diminished image of the object  $AB$  and is formed between  $F$  and  $2F$ .

**Question 14.**

Mention one difference between reflection of light from a plane mirror and total internal reflection of light from a prism.

**Answer:**

In the case of a plane mirror, the reflection of light incident on the mirror takes place for all angles of incidence. In the case of total internal reflection of the light incident on a prism, the incident ray is first refracted and then suffers total reflection from the other face only, if light is incident at an angle greater than the critical angle.

Whereas a lot of light energy is absorbed in ordinary reflection, no light is absorbed during total internal reflection.

**Question 15.**

The diagram given below shows a right-angled prism with a ray of light incident on the side AB. (The critical angle for glass is  $42^\circ$ ).

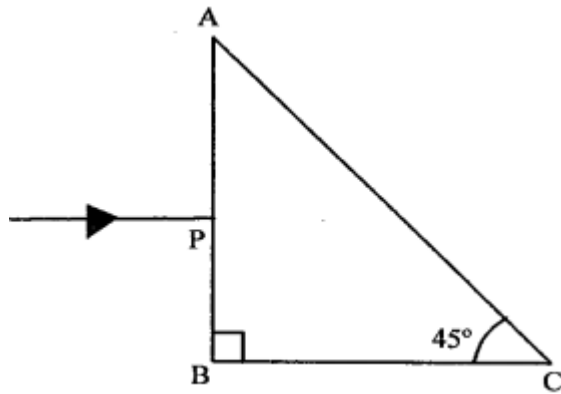

1. Copy the diagram and complete the path of the ray of light in and out of the glass prism.
2. What is the value of the angle of deviation shown by the ray ?

**Answer:**

1. The required diagram is as shown in the fig.
2. The angle of deviation is  $90^\circ$  as shown.

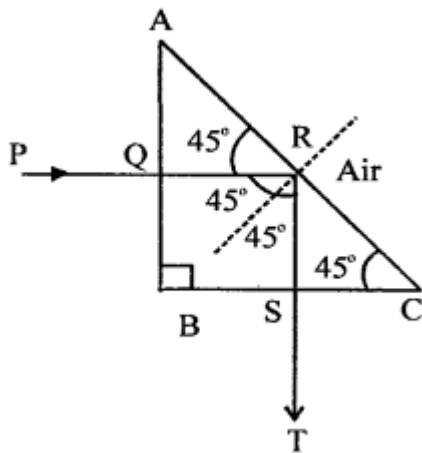

**Question 16.**

1. With the help of a well-labelled diagram show that the apparent depth of an object, such as a coin, in water is less than its real depth.
2. How is the refractive index of water related to the real depth and the apparent depth of a column of water ?

**Answer:**

(i) The labelled diagram is as shown. Coin is placed at position A. It appears at a position B.

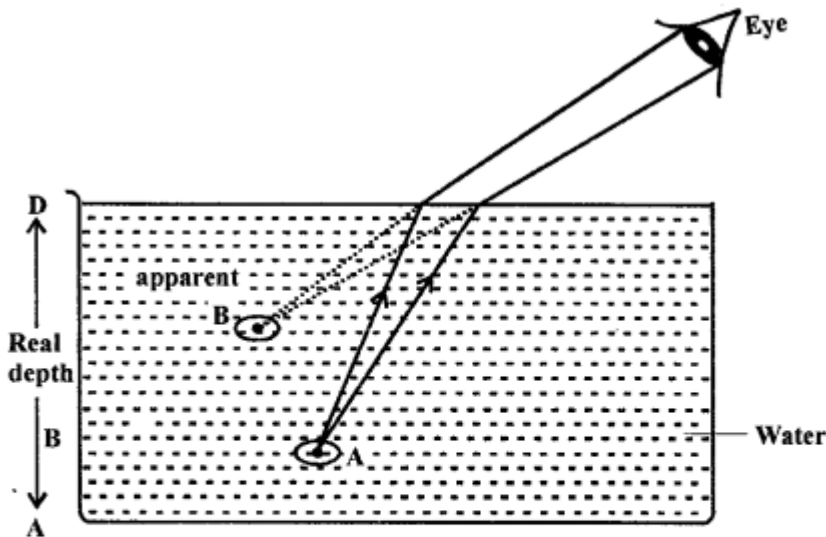

Here,

AO = real depth

AI = apparent depth

(ii) The required relation is

$$\mu = \frac{\text{real depth}}{\text{apparent depth}}$$

2008

**Question 17.**

(a) (i) A monochromatic beam of light of wavelength  $\lambda$  passes from air into a glass block. Write an expression to show the relation between the speed of light in air and the speed of light in glass.

(ii) As the ray of light passes from air to glass, state how the wavelength of light changes. Does it increase, decrease or remain constant ?

(b) Draw a ray diagram to illustrate the determination of the focal length of a convex lens using an auxiliary plane mirror.

**Answer:**

(a) When a ray of light of wavelength  $\lambda$  passes from air into denser medium speed of light in glass decreases

$V = v\lambda$  frequency  $v$  remains same wave length ' $\lambda$ ' decrease

$$\therefore \frac{c}{v} = \frac{\text{vel. of light in air}}{\text{vel. of light in glass}} = \frac{v\lambda}{v\lambda'} = \frac{\lambda}{\lambda'}$$

(ii) Wavelength decrease when a ray of light goes from air to glass

(b) On placing lens L on a plane mirror MM' the pin P is clamped so that its tip is vertically above the centre O of the lens L then height of the pin is adjusted to remove parallax and distance x of the pin from the lens is measured and the distance y of the pin from mirror is measured. The average of the two distances gives the focal length of the lens.

$$f = \frac{x+y}{2}$$

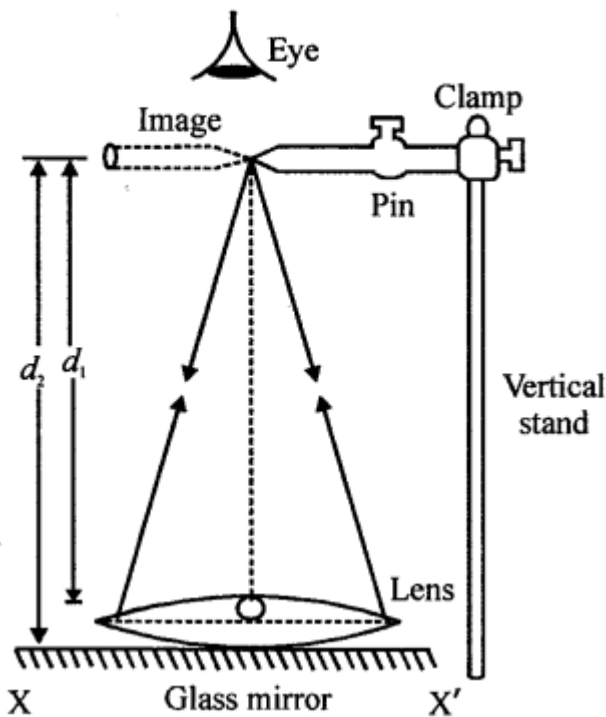

**Question 18.**

- (a) (i) Draw a labelled ray diagram to illustrate (1) critical angle (2) total internal reflection, for a ray of light moving from one medium to another.  
(ii) Write a formula to express the relationship between refractive index of the denser medium with respect to rarer medium and its critical angle for that pair of media.
- (b) (i) The diagram below shows a ray of light incident on an equilateral glass prism placed in minimum deviation position.

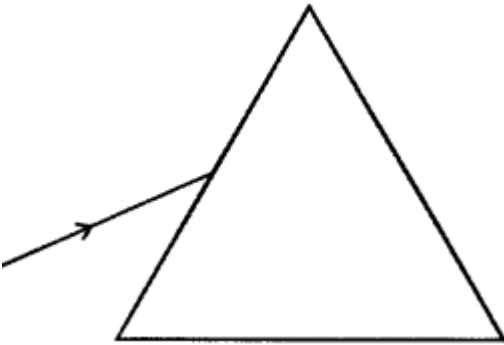

Copy the diagram and complete it to show the path of the refracted ray and the emergent ray.

(ii) How are angle of incidence and angle of emergence related to each other in this position of the prism ?

**Answer:**

(a) (i)

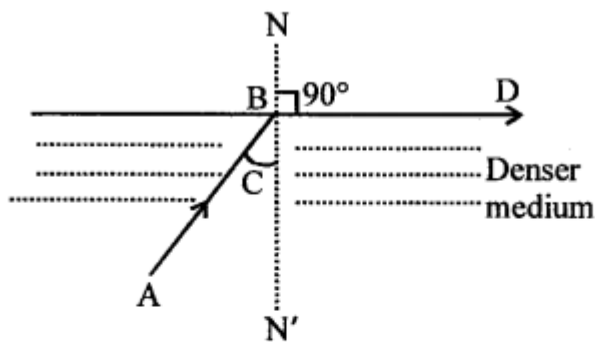

$\angle ABN' = C =$  Critical angle for which angle of refraction  $\angle NBD = 90^\circ$  and refracted ray is parallel to the surface.

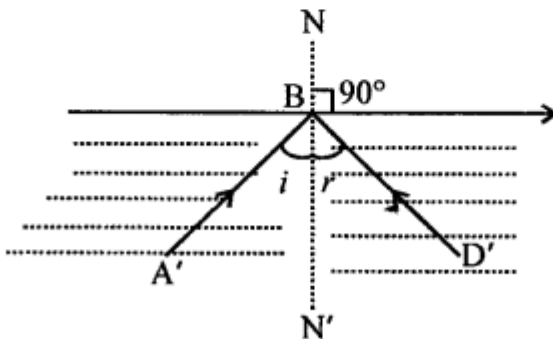

Angle of incidence  $\angle A'BN' > \angle C$

Refraction in the same medium takes place  $\angle i = \angle r$

(ii) Refractive index of denser medium (glass) w.r.t. rarer medium (air)

$$= {}^g\mu_a = \frac{\text{velocity of light in glass}}{\text{velocity of light in air}}$$

$${}^g\mu_a = \frac{\sin i_c}{\sin 90^\circ}$$

$$\sin i_c = {}^g\mu_a \quad (\because \sin 90^\circ = 1)$$

(b) (i)  $\angle LMO$  = angle of minimum deviation

OB is incident ray produced to L

QE is emergent ray produced in the backward direction to meet OL at M.

BQ is refracted ray

(ii) Angle of incidence = Angle of emergence.

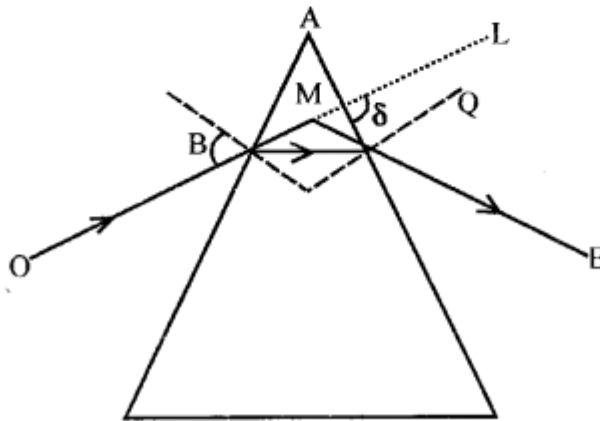

(ii) In minimum deviation position  $\angle i_1 = \angle i_2$  that is angle of incidence = angle of emergence.

### Question 19.

A linear object is placed on the axis of a lens. An image is formed by refraction in the lens. For all positions of the object on the axis of the lens, the positions of the image are always between the lens and the object

(a) Name the lens.

(b) Draw a ray diagram to show the formation of the image of an object placed in front of the lens at any position of your choice except infinity.

**Answer:**

- (a) As the position of image is always between the lens and the object i.e. on the left of lens it is concave lens.
- (b) Object lies anywhere between infinity and optical centre.

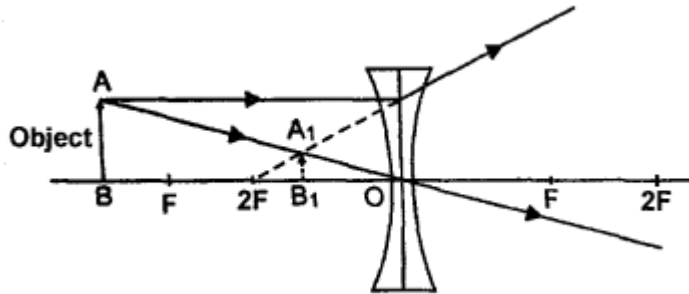

The image is formed between F and optical centre is virtual erect and diminished.

**Question 20.**

Two isosceles right-angled prisms are placed near each other as shown in the figure.

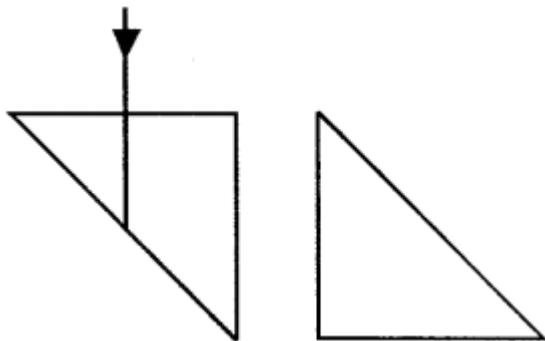

Complete the path of the light ray entering the first isosceles right-angled glass prism till it emerges from the second identical prism.

**Answer:**

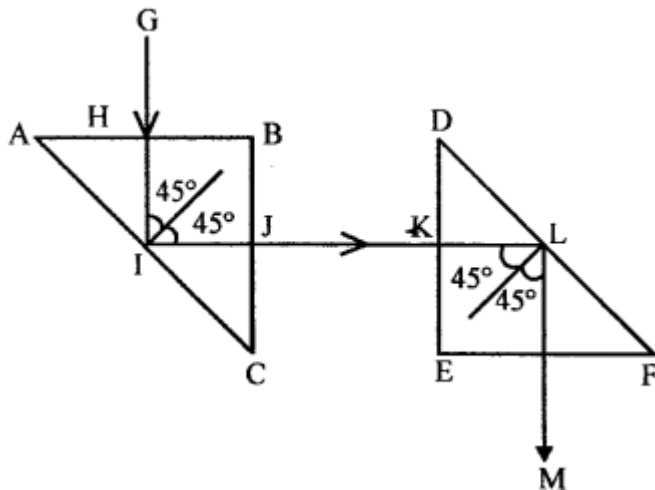

**Question 21.**

(a) A ray of light strikes the surface of a rectangular glass block such that the angle of incidence is (i)  $0^\circ$  (ii)  $42^\circ$ . Sketch a diagram to show the approximate path taken by the ray in each case as it passes through the glass block and emerges from it.

**Answer:**

(a) (i)

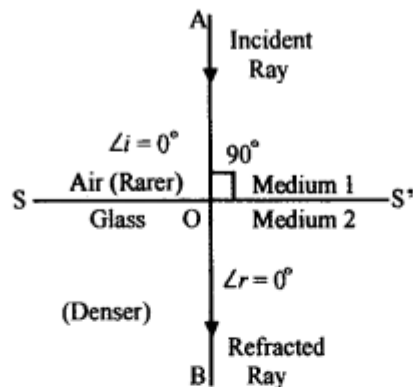

Angle of incidence =  $0^\circ$ . The ray will pass through glass block undeviated and emerge out making angle of refraction.

(ii)

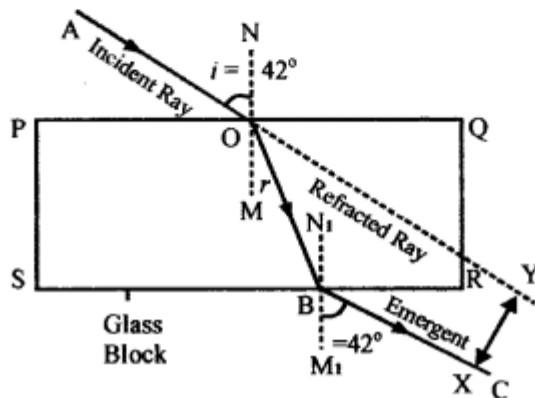

Angle of incidence  $42^\circ$  = critical angle of glass, the refracted ray makes angle of  $90^\circ$  and emerges parallel to the surface along BC.

(b) State the conditions required for total internal reflection of light to take place.

**Answer:**

**Conditions required for total internal reflection to take place :**

1. Light must travel from denser to rarer medium.
2. Angle of incidence in denser medium must be greater than critical angle for the pair of media.

**(c) Copy and complete the following table :**

<i>Types of lens</i>	<i>Position of Object</i>	<i>Nature of Image</i>	<i>Size of Image</i>
<i>Convex</i>	<i>At F</i>		
<i>Concave</i>	<i>At infinity</i>		

**Ans.**

<b>Types of lens</b>	<b>Position of Object</b>	<b>Nature of Image</b>	<b>Size of Image</b>
Convex	At F	Real, inverted	Highly magnified
Concave	At infinity	Virtual, erect	Diminished

**Question 22.**

(a) How does the value of angle of deviation produced by a prism change with an increase in the :

1. value of angle of incidence
2. wavelength of incident light ?

**Answer:**

1. When the angle of incidence increases angle of deviation first decreases till it reaches the value known as minimum deviation position. After that with the increase in angle of incidence angle of deviation also increases.
2. Angle of deviation decreases with increase in the wavelength of light, so angle of deviation is maximum for violet light and least for red light.

(b) (i) Copy and complete the diagram to show the formation of the image of the subject AB.

(ii) What is the name given to x ?



(i)

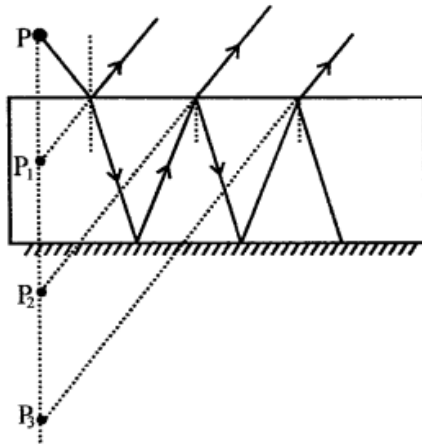

(ii) Image formed by  $I_2$  is brightest because it is formed by reflection as well as refraction.

2010

**Question 23.**

(a) (i) What is meant by refraction of light ?

(ii) What is the cause of refraction of light ?

(b) 'The refractive index of diamond is 2.42 ; What is meant by this statement ?

(c) We can burn a piece of paper by focussing the sun rays by using a particular type of lens.

(i) Name the type of lens used for the above purpose.

(ii) Draw a ray diagram to support your answer.

(d) A ray of light enters a glass slab PQRS, as shown in the diagram. The critical angle of the glass is  $42^\circ$ . Copy this diagram and complete the path of the ray till it emerges from the glass slab Mark the angle in the diagram wherever necessary.

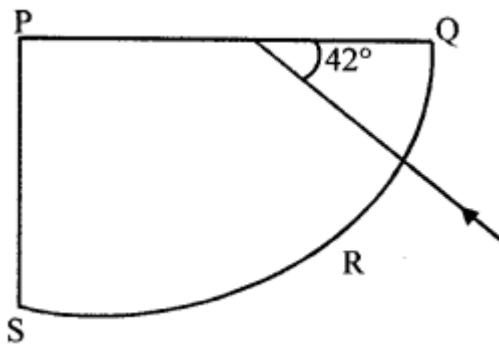

**Answer:**

(a) (i) Refraction of Light : "When light travels from one optical medium to other optical medium, it changes its path, . this change in path is called refraction of light."

(ii) The refraction of light takes place because the velocity of light in different media is different.

(b) R.I of diamond is 2.42 this means that velocity of light in diamond is  $1/2.42$  times the vel. of light in air.

(c) (i) A convex lens is used to focus the sun rays on a piece of paper to burn it. A large amount of heat gets concentrated at a point and is sufficient to burn the piece of paper.

(ii) The necessary ray diagram is given below.

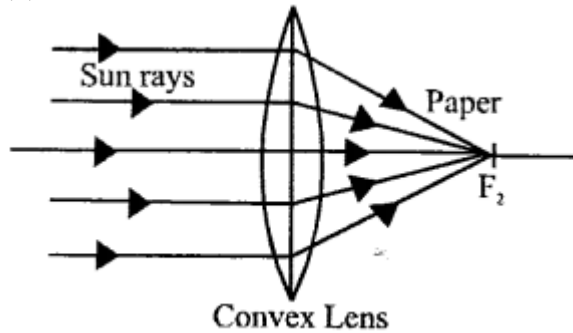

(d) The copied diagram alongwith the complete path of the ray is as shown below :

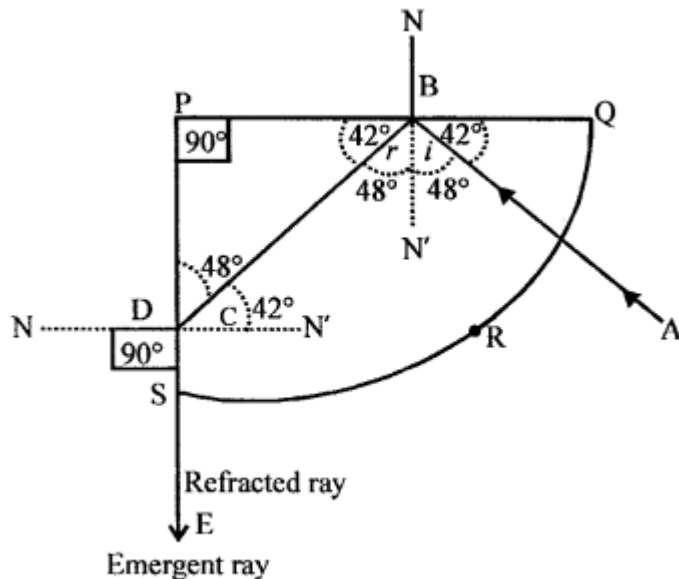

The angle of incidence on PQ is  $48^\circ$  which is greater than the critical angle. Hence, total internal reflection takes place at PQ. OT is the totally reflected ray. It is incident on PS at  $42^\circ$  and will be refracted along TS.

**Question 24.**

(a) A stick partly immersed in water appears to be bent. Draw a ray diagram to show the bending of the stick when placed in water and viewed obliquely from above.

(b) A ray of monochromatic light is incident from air on a glass slab :

1. Draw a labelled ray diagram showing the change in the path of the ray till it emerges from the glass slab.
2. Name the two rays that are parallel to each other. (Hi) Mark the lateral displacement in your diagram.

(c) An erect, magnified and virtual image is formed, when an object is placed between the optical centre and principal focus of a lens.

1. Name the lens.
2. Draw a ray diagram to show the formation of the image with the above stated characteristics. (4)

**Answer:**

(a)

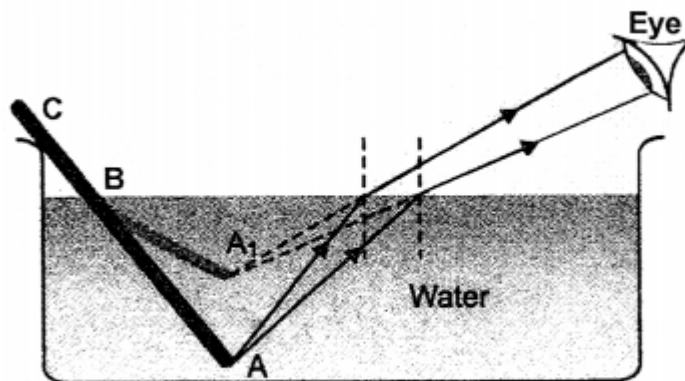

The stick appears to be bent upwards and seems to be shortened. This is due to refraction of light.

(b) (i)

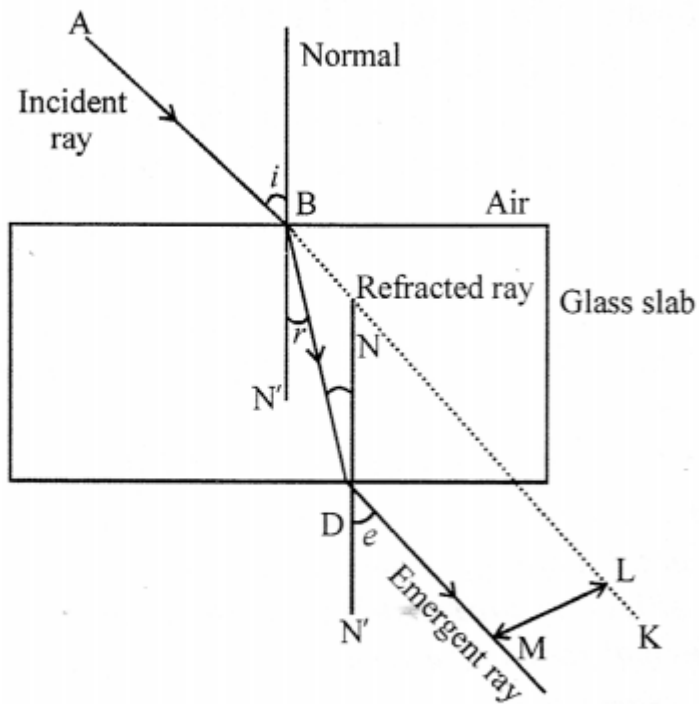

(ii) Incident ray is parallel to emergent ray.

(iii) PQ is the lateral displacement.

(c) (i) Lens is convex or converging lens.

(ii)

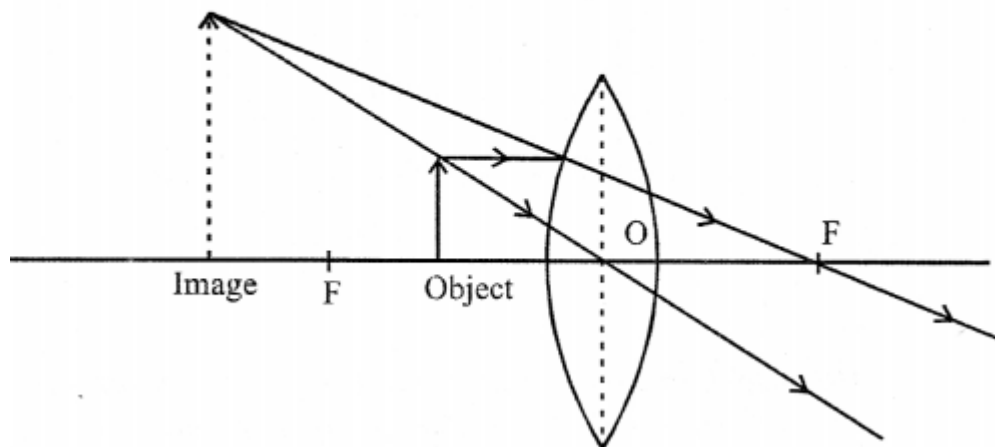

2011

**Question 25.**

(a) (i) Copy the diagram and complete the path of the ray of light through the glass block. In your diagram, mark the angle of incidence by letter "i" and the angle of emergence by the letter "e"

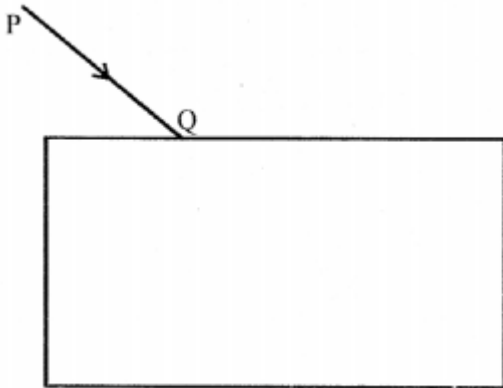

(ii) How are the angle 'i' and 'e' related to each other?

(b) A ray of monochromatic light enters a liquid from air as shown in the diagram.

(i) Copy the diagram and show in the diagram the path of the ray of light after it strikes the mirror and reenters the medium of air.

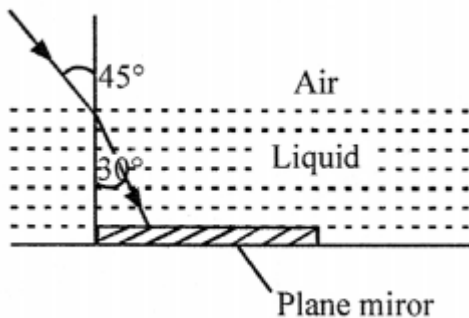

(ii) Mark in your diagram the two angles on the surface of separation when the ray of light moves out from the liquid to air.

(c) (i) When does a ray of light falling on a lens pass through it undeviated ?

(ii) Which lens can produce a real and inverted image of an object ?

(d) (i) How is the refractive index of a medium related to its real depth and apparent depth?

(ii) Which characteristic property of light is responsible for the blue colour of the sky ?

**Answer:**

(a) (i)

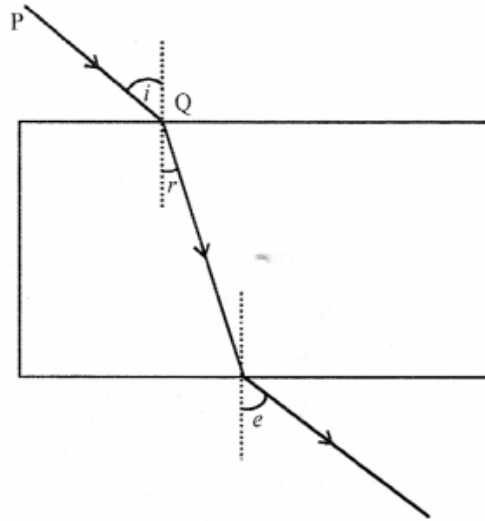

(ii)  $\angle i = \angle e$  (Corresponding angles)

(b) (i),  $\angle i = 30^\circ$ ,  $\angle r = 45^\circ$

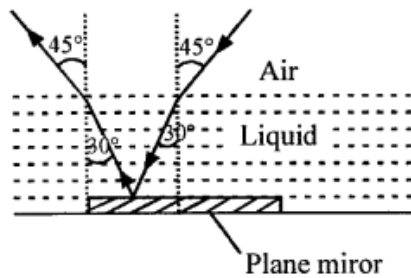

(c) (i) A ray of light passing through the optical centre of the lens passes through it undeviated.

(ii) Convex lens.

(d) (i)  $\text{Refractive index} = \frac{\text{Real depth}}{\text{Apparent depth}}$

(ii) Effects of scattering.

The blue or violet light due to its short wavelength is scattered more as compared to red light of long wavelength.

### Question 26.

(a) (i) State the laws of refraction of light.

(ii) Write a relation between the angle of incidence ( $i$ ), angle of emergence ( $e$ ), angle of prism ( $A$ ) and angle of deviation ( $d$ ) for a ray of light passing through an equilateral prism.

(b) An object is placed in front of a lens between its optical centre and the focus and

forms an erect, virtual, and diminished image.

(i) Name the lens which formed this image.

(ii) Draw a ray diagram to show the formation of the image.

**Answer:**

(a)

**(i) Laws of Refraction :**

(a) The incident ray, the refracted ray and the normal at the point of incidence, all lie in the same plane.

(b) The ratio of the sine of the angle of incidence to the sine of the angle of refraction is constant for the pair of given media.

**(ii)  $\angle i + \angle e = A + d$**

**(b)**

(i) Lens is concave.

(ii) AD is object between focus and optical centre A'D' is image. The ray diagram is shown.

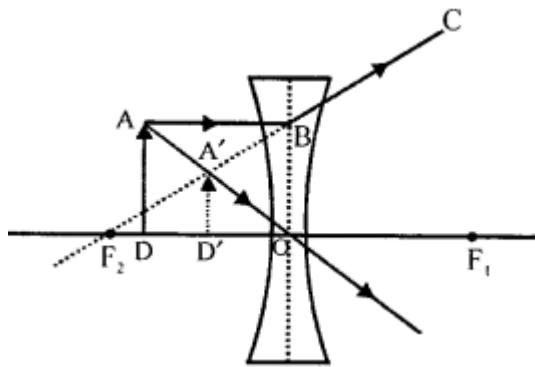

2012

**Question 27.**

**(a)**

(i) Define refractive index of a medium in terms of velocity of light.

(ii) A ray of light moves from a rare medium to a dense medium as shown in the diagram below. Write down the number of the ray which represents the partially reflected ray.

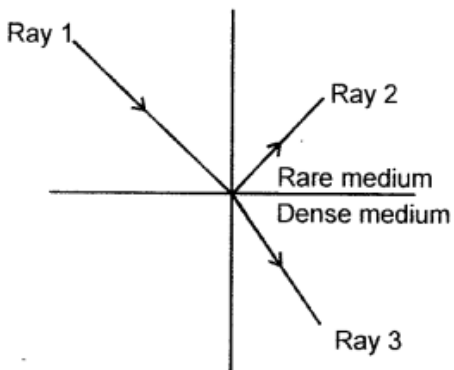

- (b) You are provided with a printed piece of paper. Using this paper how will you differentiate between a convex lens and a concave lens ?
- (c) A ray of light incident at an angle of incidence 'V' passes through an equilateral glass prism such that the refracted ray inside the prism is parallel to its base and emerges from the prism at an angle of emergence 'e'
- (i) How is the angle of emergence 'e' related to the angle of incidence 'i' ?
- (ii) What can you say about the value of the angle of deviation in such a situation ?

**Answer:**

- (a) (i) Refractive index of a medium is the ratio of velocity of light in vacuum or air to the velocity of light in a given medium.

$$R.I. = \frac{v_{air}}{v_{medium}} \mu_{medium}$$

- (ii) Ray 2, represents partially reflected ray.
- (b) Hold each of the lens 5 cm above the printed paper and look for the image. In case of convex lens the print appears enlarged. However, in case of concave lens, the print appears diminished.
- (c) (i) Angle of incidence is equal to the angle of emergence
- (ii) The angle of deviation is minimum in this particular case.

**Question 28.**

- (a)
- (i) What is meant by the term 'critical angle' ?
- (ii) How is it related to the refractive index of the medium?
- (iii) Does the depth of a tank of water appear to change or remain the same when viewed normally from above ?
- (b) A ray of light PQ is incident normally on the hypotenuse of a right angled prism ABC as shown in the diagram given alongside :

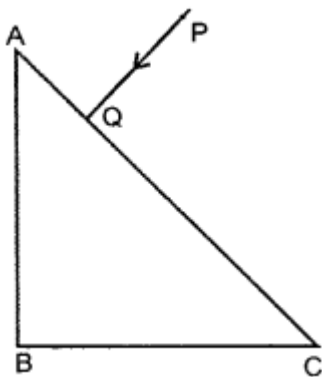

- (i) Copy the diagram and complete the path of the ray PQ till it emerges from the prism.
- (ii) What is the value of the angle of deviation of the ray ?
- (iii) Name an instrument where the action of the prism is used.
- (c) A converging lens is used to obtain an image of an object placed in front of it.

The inverted image is formed between  $F_2$  and  $2F_2$  of the lens.

(i) Where is the object placed ?

(ii) Draw a ray diagram to illustrate the formation of the image.

**Answer:**

(a) (i) The angle of incidence in a denser medium for which angle of refraction in rarer medium is  $90^\circ$  is called critical angle.

(ii) Refractive index ( $\mu$ ) =  $1/\sin C$

(iii) The depth of tank remains same when viewed normally from above.

(b) (i)

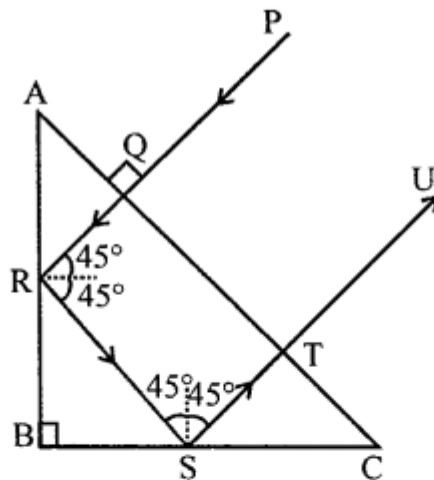

(ii) The ray deviates through  $180^\circ$ .

(iii) This action of prism is used in camera to invert the image.

(c) (i) The object is anywhere here between  $2F_1$  and infinity.

(ii)

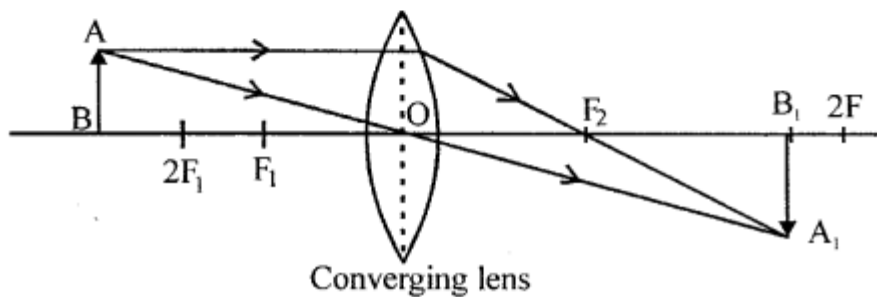

2013

**Question 29.**

(a) A ray of light is moving from a rarer medium to a denser medium and strikes a plane mirror placed at  $90^\circ$  to the direction of the ray as shown in the diagram.

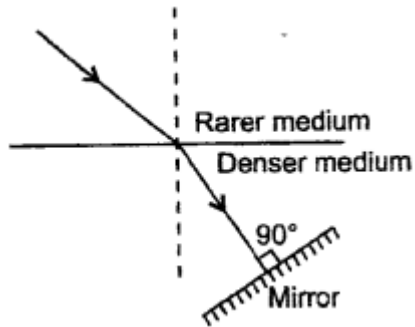

- (i) Copy the diagram and mark arrows to show the path of the ray of light after it is reflected from the mirror.
- (ii) Name the principle you have used to mark the arrows to show the direction of the ray.
- (b)** (i) The refractive index of glass with respect to air is 1.5. What is the value of the refractive index of air with respect to glass ?
- (ii) A ray of light is incident as a normal ray on the surface of separation of two different mediums. What is the value of the angle of incidence in this case ?
- (c)** (i) Can the absolute refractive index of a medium be less than one ?
- (ii) A coin placed at the bottom of a beaker appears to be raised by 4.0 cm. If the refractive index of water is  $\frac{4}{3}$ , find the depth of the water in the beaker.
- (d)** An object AB is placed between  $2F_1$  and  $F_1$  on the principal axis of a convex lens as shown in the diagram.

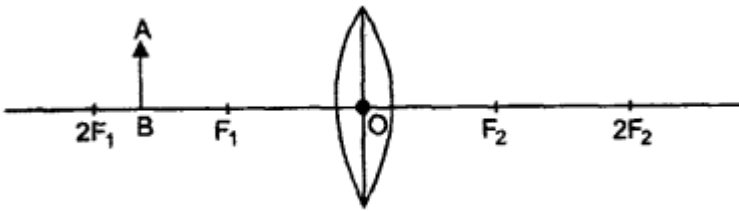

Copy the diagram and using three rays starting from point A, obtain the image of the object formed by the lens.

**Answer:**

(a) (i)

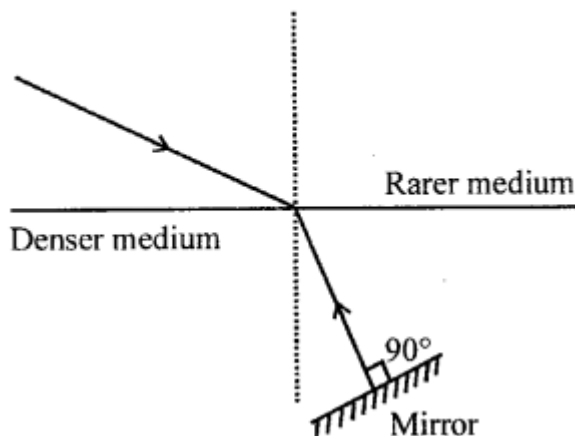

(ii) The principle is the law of reversibility of light

(b) (i) R.I. of glass  ${}^a\mu_g = 1.5$

$\therefore$  R.I of air with respect to glass

$${}^g\mu_a = \frac{1}{{}^a\mu_g} = \frac{1}{1.5} = \frac{2}{3} = 0.67 \text{ (Approx.)}$$

(ii) Angle of incidence is zero. *i.e.*  $\angle i = 0$

(c) (i) Yes, when a ray travels from glass (or any denser medium) to air, the absolute refractive index of air is less than 1.

(ii) Let the real depth of water =  $x$

Apparent depth of water =  $(x - 4)$  cm.

$$\text{Now, refractive index of water} = \frac{\text{Real depth}}{\text{Apparent depth}} \Rightarrow \frac{4}{3} = \frac{x}{x - 4}$$

$$\text{or } (4x - 16) = 3x$$

$$\therefore \text{Real depth} = x = 16 \text{ cm}$$

(d)

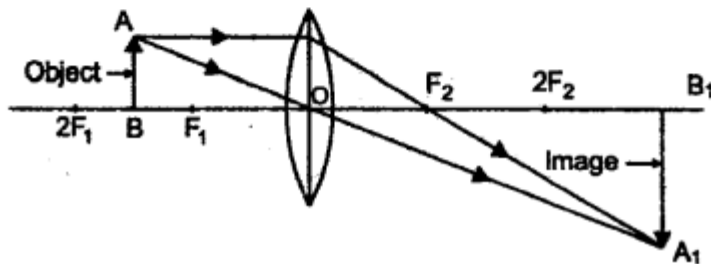

2014

**Question 30.**

(a) Draw the diagram given below and clearly show the path taken by the emergent ray.

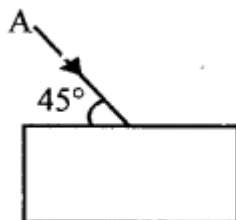

(b) (i) A ray of light passes from water to air. How does the speed of light change?

- (ii) Which colour of light travels fastest in any medium except air? [2]  
 (c) Name the factors affecting the critical angle for the pair of media.

**Answer:**

(a)

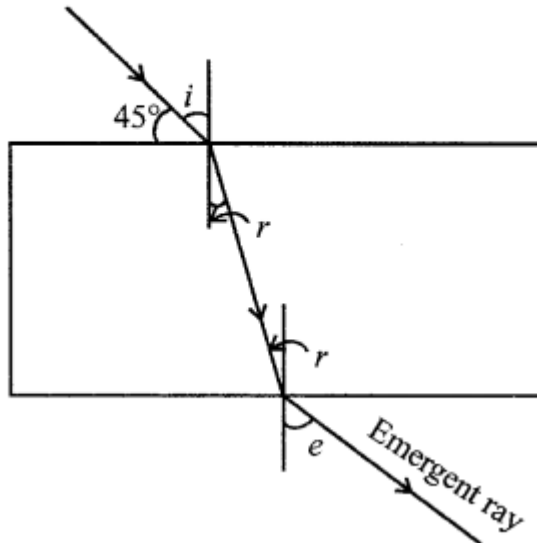

- (b) (i) As the ray of light comes out of water into air (rarer medium) speed of light increases.  
 (ii) Red colour of light travels fastest in any medium except air.  
 (c) Factors affecting the critical angle for the pair of media are :  
 (i) Effect of colour (least for violet, most for red)  
 (ii) Effect of Temperature i.e. an increasing the temperature of medium, critical angle increases

**Question 31.**

- (a) (i) Light passes through a rectangular glass slab and through a triangular glass prism. In what way does the direction of the two emergent beams differ and why?  
 (ii) Ranbir claims to have obtained an image twice the size of the object with a concave lens. Is he correct? Give a reason for your answer. [4]  
 (b) A lens forms an erect, magnified and virtual image of an object.  
 (i) Name the lens.  
 (ii) Draw a labelled ray diagram to show the formation of the image.  
 (c) (i) Define the power of a lens.  
 (ii) The lens mentioned in 2(b) above is of focal length 25 cm. Calculate the power of the lens.

**Answer:**

- (a) In case of glass slab the refraction takes place at two parallel surfaces. On the first surface, the colours are separated and dispersion takes place.

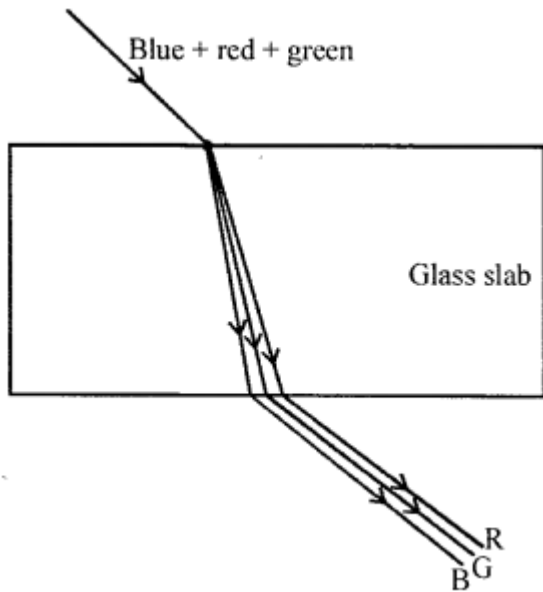

On the second surface refraction takes place and emergent ray is parallel to the incident ray on the first surface and emergent ray appears to be almost white. In a prism, refraction takes place at two INCLINED surfaces and causes DISPERSION and DEVIATION of light and spectrum is seen.

(ii) No, he is not correct.

With concave lens, image formed is always DIMINISHED

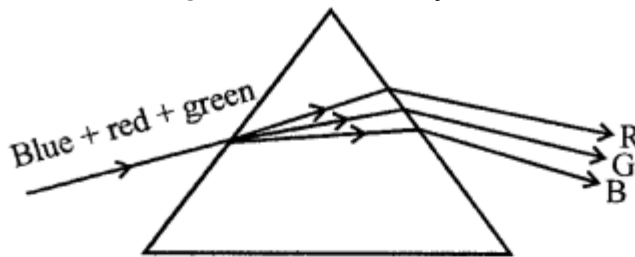

(b) (i) Convex lens.

(ii)

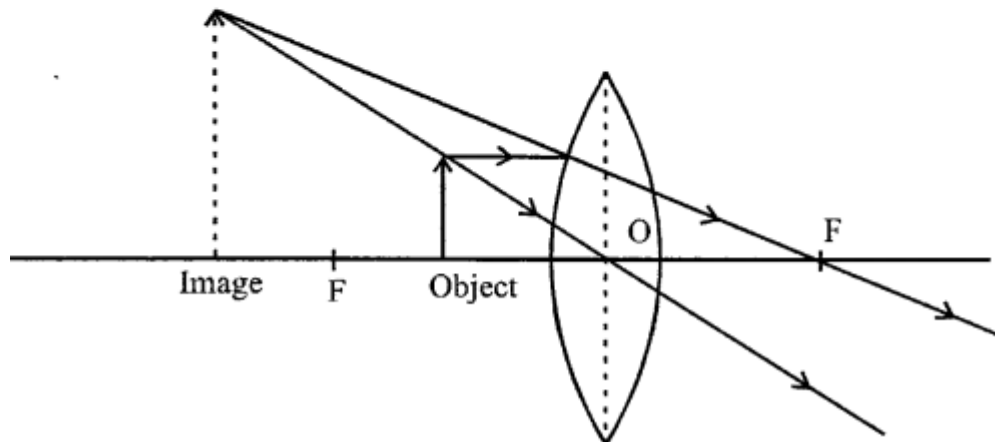

(c) (i) The power of a lens is a measure of deviation produced by it in the path of rays refracted through it.

$$(ii) \text{ Power of lens (in D)} = \frac{1}{\text{Focal length (in metre)}}$$

$$= \frac{100}{\text{Focal length (in centimetre)}}$$

$$= \frac{100}{25} = 4D.$$

2015

### Question 32.

1. Name one factor that affects the lateral displacement of light as it passes through a rectangular glass block.
2. The speed of light in glass is  $2 \times 10^8$  km/s. What is the refractive index of glass?

### Answer:

1. The thickness of the glass block, angle of incidence and refractive index of glass (any one) are the factors which affect the lateral displacement of light as it passes through a rectangular glass slab.
2. **Given :**  
Speed of light in glass =  $2 \times 10^8$  km/s =  $2 \times 10^8$  m/s  
Refractive index of glass is

$$\mu_{\text{glass}} = \frac{\text{Speed of light in air}}{\text{Speed of light in glass}} = \frac{3 \times 10^8 \text{ km/s}}{2 \times 10^8 \text{ km/s}} = 1.5$$

### Question 33.

- (a) (i) Where should an object be placed so that a real and inverted image of the same size as the object is obtained using a convex lens ?
- (ii) Draw a ray diagram to show the formation of the image as specified in the part a(i).

### Answer:

- (i) When an object is placed at  $2F_1$  of a convex lens, a real and inverted image of the same size as that of the object is formed at  $2F_2$
- (ii) The ray diagram for the same is as shown below :

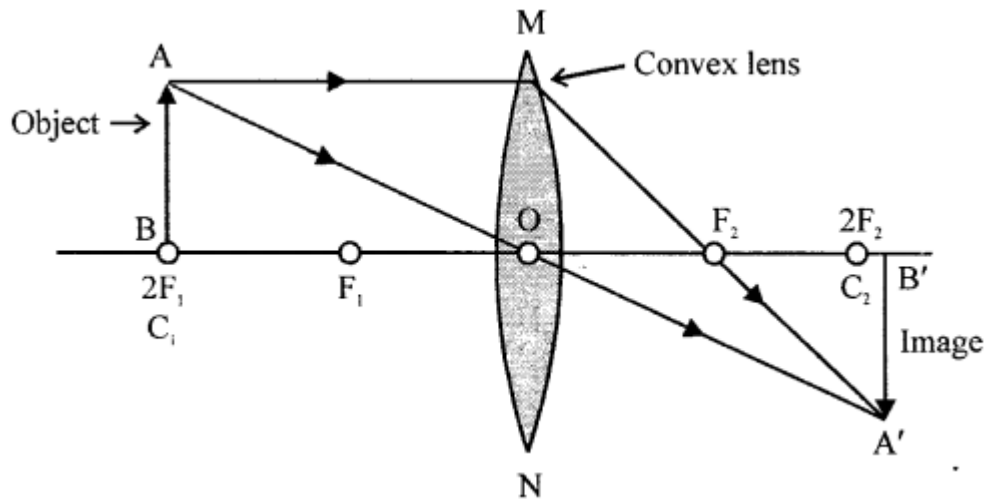

(b) Jatin puts a pencil into a glass container having water and is surprised to see the pencil in a different state. [4]

- (i) What change is observed in the appearance of the pencil?
- (ii) Name the phenomenon responsible for the change.
- (iii) Draw a ray diagram showing how the eye sees the pencil.

**Answer:**

1. The pencil appears to be broken at the junction of water, air separation i.e. it also appears shorter and raised.
2. The phenomenon responsible for the above observation is the refraction of light and APPARANT DEPTH in passing from water to air.
3. The ray diagram for the same is as shown below :

**2016**

**Question 34.**

(a) A boy uses blue colour of light to find refractive index of glass. He then repeats experiment using red colour of light. Will the refractive index be same or different in the two cases? Give a reason to support your answer.

**Answer:**

The refractive index will be different in both cases. Refractive index of glass is different for different colours. The speed of blue light is less than the speed of red light. So, the wavelength of blue light is less than that of red light. Thus, red light would deviate less than blue light because of difference in wavelength.

(b)

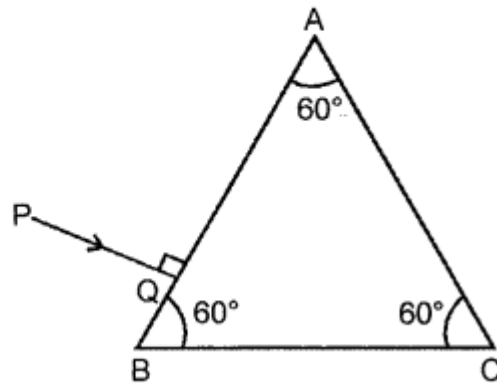

Copy the diagram given above and complete the path of ray till it emerges out of prism. The critical angle of glass is  $42^\circ$ . In your diagram mark the angles wherever necessary.

**Answer:**

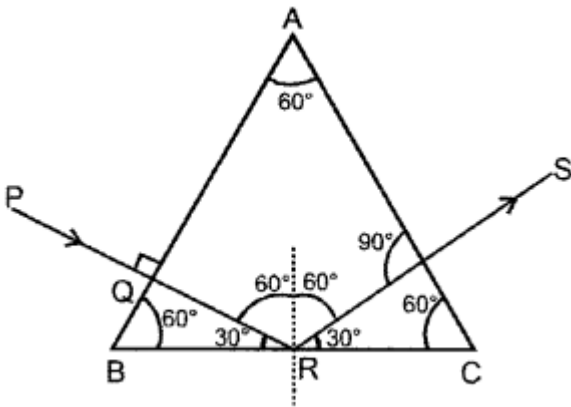

(c) State the dependence of angle of deviation :

1. On refractive index of a material of prism.
2. On the wavelength of light

**Answer:**

(i) Angle of deviation is directly proportional to the refractive index of the material of prism. For a given angle of incidence, the prism with higher refractive index produces a greater deviation than the prism which has a lower refractive index. Thus, the angle of deviation increases with an increase in the refractive index of the medium.

(ii) Angle of deviation is inversely proportional to the wavelength of the light used. The angle of deviation decreases with an increase in the wavelength of light. Thus, a prism deviates violet light the most and red light the least.

**Question 35.**

(a)

1. Write a relationship between the angle of incidence and the angle of refraction for a given pair of media.
2. When a ray of light enters from one medium to another medium having different optical densities, it bends, why does this phenomenon occur ?
3. Write a condition where it does not bend when entering a medium of different optical density.

(b) A lens produces a virtual image between the object and the lens.

1. Name the lens
2. Draw a ray diagram to show the formation of image.

**Answer:**

- (i) The ratio of the sine of the angle of incidence to the sine of the angle of refraction is constant for a given pair of media called the refractive index =  $\sin i / \sin r = \mu$
- (ii) When a ray of light enters from one medium to another with different optical densities, it bends because there is a change in the speed of light in the two media.
- (iii) A ray of light passing from one medium to another does not bend when it is incident normally on the surface.

(b)

(i) The image formed by the lens is virtual and between the object and the lens. Hence, the lens used is a concave lens.

(ii) The following image is of formation of the above image :

